

Total System Depth (mm)	Bracket / insulation Thickness (mm)	Thermal Performance (W/m ² K)	Acoustic Performance RW (db)	System Weight (Kg/m ²)
150	120	0.39	33	15.8
170	140	0.33	34	16.0
190	160	0.28	36	16.3
210	180	0.25	37	16.5
230	200	0.22	39	16.8
250	220	0.20	40	17.1
270	240	0.18	42	17.3
290	260	0.18	43	17.6
310	280	0.16	45	17.8
330	300	0.15	46	18.1
350	320	0.14	47	18.4
370	340	0.13	49	18.6
390	360	0.13	50	18.9
410	380	0.12	51	19.1
430	400	0.11	53	19.4

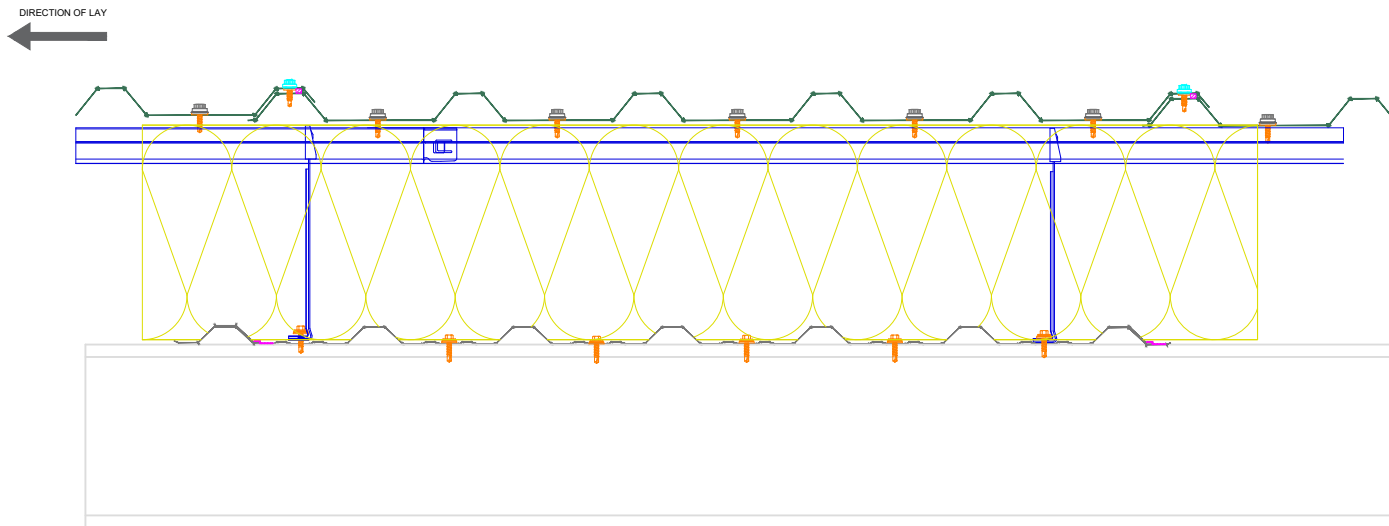

PROTEX APPROVED - SIDE LAP SEALANT
 6mm * 5mm BUTYL TAPE
LOCATION
 CONTINUOUS RUN.
 POSITIONED WEATHER SIDE OF FIXING

N1000R EXTERNAL ROOF PROFILE
 GAUGE - 0.7mm
 COATING - PROTEX APPROVED

PROTEX APPROVED - EXTERNAL MAIN FIXING
 STAINLESS STEEL SELF DRILLING & SELF TAPPING
 PAINTED / MOULDED HEAD
 19mm Ø EDPM WASHER
PATTERN
 SHEET ENDS - EVERY TROUGH - 5 NO. FIXINGS
 INTERMEDIATE SUPPORTS - ALTERNATE TROUGH - 3 NO. FIXINGS

PROTEX APPROVED - EXTERNAL STITCHER FIXING
 STAINLESS STEEL SELF DRILLING & SELF TAPPING
 PAINTED / MOULDED HEAD
 16mm Ø EDPM WASHER
PATTERN
 SIDE LAP - 450mm CENTRES

PROTEX APPROVED - SPACER SYSTEM
 BRACKET DEPTH TO SUIT U-VALUE CALCULATIONS
 MINIMUM DEPTH 120mm
PATTERN
 MAX RAIL CENTRE'S 1800mm
 MAX BRACKET CENTRE'S 1000mm
 BRACKET CENTRE'S TO SUIT LOADING CALCULATIONS
 BRACKET MUST BE PLACED WITHIN 100mm OF MALE END OF SPACER SYSTEM JOINT AND BAR END

PROTEX APPROVED - GLASS FIBRE INSULATION
 THICKNESS TO SUIT U-VALUE REQUIREMENT
 MINIMUM THICKNESS - 120mm
 FIRE CLASS A1 TO EN 13501-1
 MANUFACTURED IN ACCORDANCE WITH BS EN 13162
 (SUGGESTED THICKNESS TO BE >10% THAN SPACER SYSTEM DEPTH.)

DIRECTION OF LAY ←

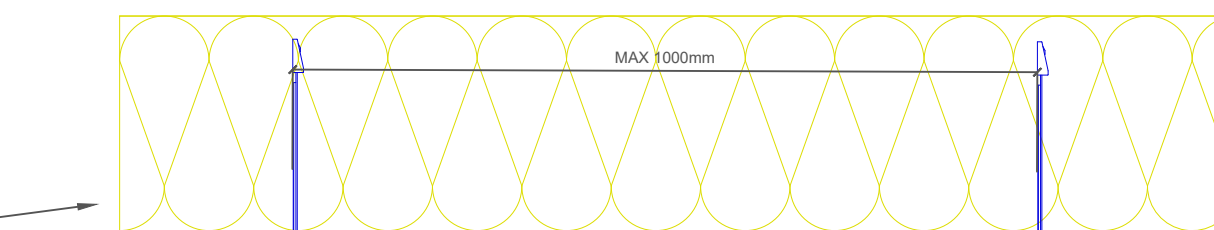
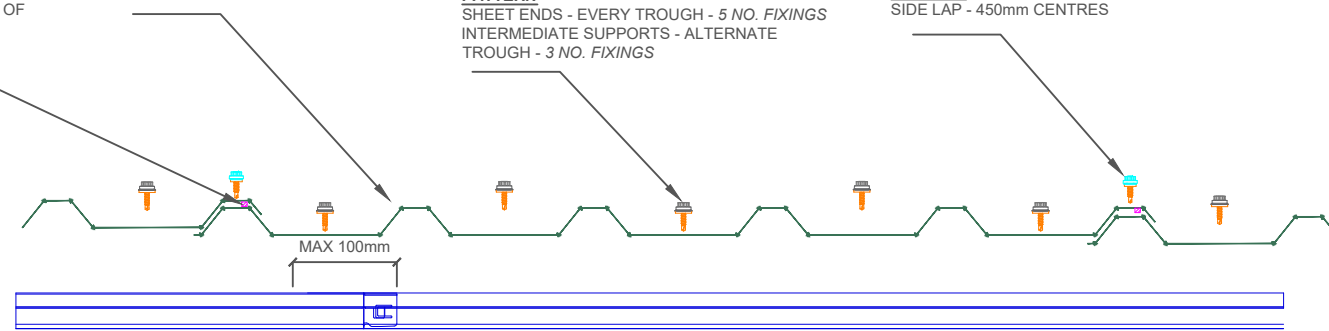

N1000L+ INTERNAL LINER PROFILE
 GAUGE - 0.4mm
 COATING - BRIGHT WHITE LINER LINER

PROTEX APPROVED - LINER SIDE LAP SEALANT
 50mm * 1mm BUTYL TAPE
LOCATION
 CONTINUOUS RUN.
 POSITIONED CENTRAL OVER JOIN

PROTEX APPROVED - LINER MAIN FIXING
 STAINLESS STEEL SELF DRILLING & SELF TAPPING
 16mm Ø EDPM WASHER
PATTERN
 SHEET ENDS - EVERY TROUGH - 6 NO. FIXINGS
 INTERMEDIATE SUPPORTS - ALTERNATE TROUGH - 4 NO. FIXINGS

PROTEX APPROVED - BRACKET FIXING
 STAINLESS STEEL SELF DRILLING & SELF TAPPING
 16mm Ø EDPM WASHER
PATTERN
 AS PER LAYOUT CALCULATIONS

- INSTALLATION NOTES**
- FLASHING JOINTS SEALED WITH BUTYL
 - FLASHING JOINTS FIXED AT 100mm CENTRES (RIVET OR STITCH)
 - FLASHINGS FIXED AT 450mm CENTRES
 - BRACKET MUST BE POSITIONED WITHIN 100mm OF END OF BAR OR MALE END JOIN
 - NO IMPACT DRIVERS OR CLUTCHLESS DRILLS
 - NO CARBON FIXINGS

REV	DATE	DESCRIPTION

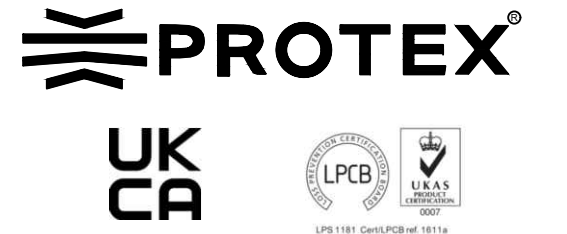

This draft drawing has been supplied by Firth Steels Ltd for guidance purposes only and is provided free of charge. It represents a suggested typical detail and should not be assumed as suitable for any specific project or application. It is essential to read this in conjunction with the Protex System specification documents to ensure completeness of information.
 Please note, no responsibility is assumed for errors or misinterpretations resulting from the information contained within this drawing. Details depicted are for illustration purposes only, and no liability is accepted for their use. Firth Steels reserves the right to modify details without notice. This drawing is the property of Firth Steels Ltd, any reproduction without explicit written consent is prohibited.
 Firth Steels is committed to ongoing improvement. The details and data shared in this document are reflective of the current state as of the issue date. It is the duty of the recipients to ensure that the information in this document is still up-to-date at the time of its use.

Drawing Number
Protex-RS02-1 Side Lap Detail

Drawn by TO	Checked by KP	Date 24/09/2024
----------------	------------------	--------------------

Project Title PRX-RS-02	Size A3	Revision A
----------------------------	------------	---------------

<<< DO NOT SCALE FROM THIS DRAWING >>>

Total System Depth (mm)	Bracket / insulation Thickness (mm)	Thermal Performance (W/m ² K)	Acoustic Performance RW (db)	System Weight (Kg/m ²)
150	120	0.39	33	15.8
170	140	0.33	34	16.0
190	160	0.28	36	16.3
210	180	0.25	37	16.5
230	200	0.22	39	16.8
250	220	0.20	40	17.1
270	240	0.18	42	17.3
290	260	0.18	43	17.6
310	280	0.16	45	17.8
330	300	0.15	46	18.1
350	320	0.14	47	18.4
370	340	0.13	49	18.6
390	360	0.13	50	18.9
410	380	0.12	51	19.1
430	400	0.11	53	19.4

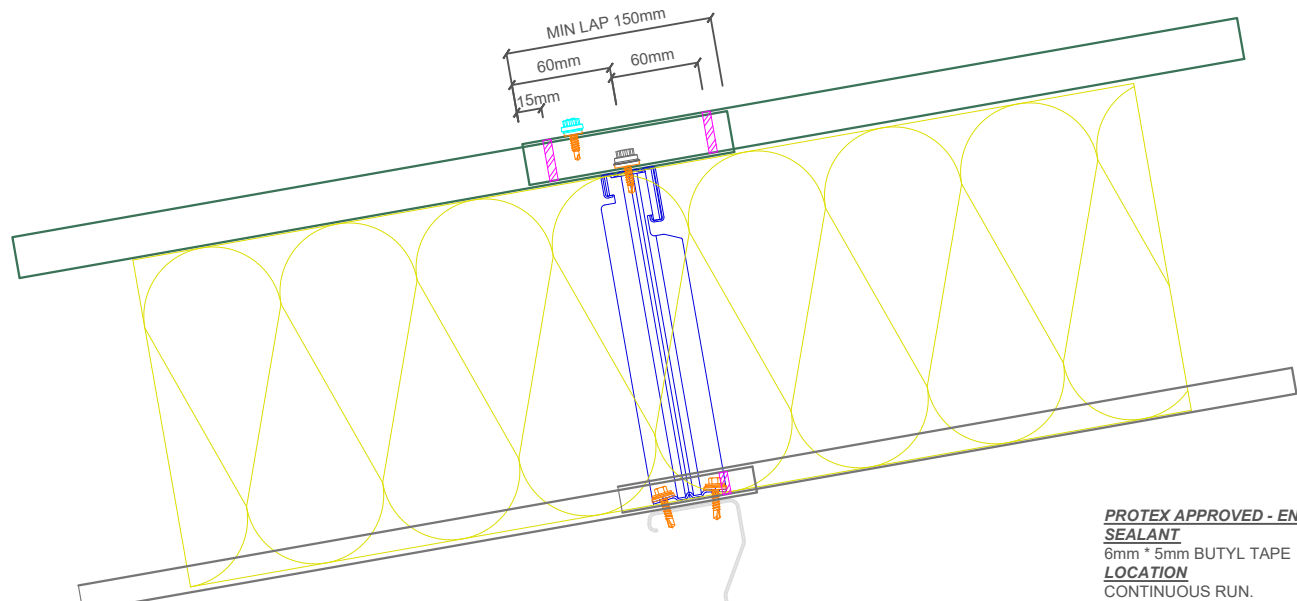

PROTEX APPROVED - END LAP SEALANT
 6mm * 5mm BUTYL TAPE
LOCATION
 CONTINUOUS RUN.
 POSITIONED IN COMPRESSION ZONE AND 15mm FROM LAP END

PROTEX APPROVED - EXTERNAL TAIL STITCHER FIXING
 STAINLESS STEEL SELF DRILLING & SELF TAPPING
 PAINTED / MOULDED HEAD
 16mm Ø EDPM WASHER
PATTERN
 SIDE LAP - 450mm CENTRES
 50mm FROM END OF SHEET

PROTEX APPROVED - EXTERNAL MAIN FIXING
 STAINLESS STEEL SELF DRILLING & SELF TAPPING
 PAINTED / MOULDED HEAD
 19mm Ø EDPM WASHER
PATTERN
 SHEET ENDS - EVERY TROUGH - 5 NO. FIXINGS
 INTERMEDIATE SUPPORTS - ALTERNATE TROUGH - 3 NO. FIXINGS

N1000R EXTERNAL ROOF PROFILE
 GAUGE - 0.7mm
 COATING - PROTEX APPROVED
 END LAP MIN 150mm

PROTEX APPROVED - SPACER SYSTEM
 BRACKET DEPTH TO SUIT U-VALUE CALCULATIONS
 MINIMUM DEPTH 120mm
PATTERN
 MAX RAIL CENTRE'S 1800mm
 MAX BRACKET CENTRE'S 1000mm
 BRACKET CENTRE'S TO SUIT LOADING CALCULATIONS
 BRACKET MUST BE PLACED WITHIN 100mm OF MALE END OF SPACER SYSTEM JOINT AND BAR END

PROTEX APPROVED - GLASS FIBRE INSULATION
 THICKNESS TO SUIT U-VALUE REQUIREMENT
 MINIMUM THICKNESS - 120mm
 FIRE CLASS A1 TO EN 13501-1
 MANUFACTURED IN ACCORDANCE WITH BS EN 13162
 (SUGGESTED THICKNESS TO BE >10% THAN SPACER SYSTEM DEPTH.)

N1000L+ INTERNAL LINER PROFILE
 GAUGE - 0.4mm
 COATING - BRIGHT WHITE LINER
 LINER MIN END LAP 100mm

PROTEX APPROVED - LINER END LAP SEALANT
 4mm / 9mm * 3mm BUTYL TAPE
LOCATION
 CONTINUOUS RUN.
 POSITIONED 25mm FROM END

PROTEX APPROVED - BRACKET FIXING
 STAINLESS STEEL SELF DRILLING & SELF TAPPING
 16mm Ø EDPM WASHER
PATTERN
 AS PER LAYOUT CALCULATIONS

PROTEX APPROVED - LINER MAIN FIXING
 STAINLESS STEEL SELF DRILLING & SELF TAPPING
 16mm Ø EDPM WASHER
PATTERN
 SHEET ENDS - EVERY TROUGH - 6 NO. FIXINGS
 INTERMEDIATE SUPPORTS - ALTERNATE TROUGH - 4 NO. FIXINGS

REV	DATE	DESCRIPTION



This draft drawing has been supplied by Firth Steels Ltd for guidance purposes only and is provided free of charge. It represents a suggested typical detail and should not be assumed as suitable for any specific project or application. It is essential to read this in conjunction with the Protex System specification documents to ensure completeness of information.
 Please note, no responsibility is assumed for errors or misinterpretations resulting from the information contained within this drawing. Details depicted are for illustration purposes only, and no liability is accepted for their use. Firth Steels reserves the right to modify details without notice. This drawing is the property of Firth Steels Ltd, any reproduction without explicit written consent is prohibited.
 Firth Steels is committed to ongoing improvement. The details and data shared in this document are reflective of the current state as of the issue date. It is the duty of the recipients to ensure that the information in this document is still up-to-date at the time of its use.

Drawing Number Protex-RS02-2 End Lap Detail			
Drawn by TO	Checked by KP	Date 24/09/2024	
Project Title PRX-RS-02		Size A3	Revision A

- INSTALLATION NOTES**
- FLASHING JOINTS SEALED WITH BUTYL
 - FLASHING JOINTS FIXED AT 100mm CENTRES (RIVET OR STITCH)
 - FLASHINGS FIXED AT 450mm CENTRES
 - BRACKET MUST BE POSITIONED WITHIN 100mm OF END OF BAR OR MALE END JOIN
 - NO IMPACT DRIVERS OR CLUTCHLESS DRILLS
 - NO CARBON FIXINGS

<<< DO NOT SCALE FROM THIS DRAWING >>>

PROTEX APPROVED - EXTERNAL STITCHER FIXING
 STAINLESS STEEL SELF DRILLING & SELF TAPPING
 POPPY RED -PAINTED / MOULDED HEAD
 16mm Ø EDPM WASHER
PATTERN
 SIDE LAP - 300mm CENTRES
 50mm FROM SHEET END

PROTEX APPROVED - END LAP SEALANT
 6mm * 5mm BUTYL TAPE
LOCATION
 3NO CONTINUOUS RUN

PROTEX APPROVED - SIDE FLASHINGS
 THICKNESS - 0.7mm
 COLOUR - BRIGHT WHITE LINER
 COATING - PROTEX APPROVED

PROTEX APPROVED - BRACKET FIXING
 STAINLESS STEEL SELF DRILLING & SELF TAPPING
 16mm Ø EDPM WASHER
PATTERN
 AS PER LAYOUT CALCULATIONS

PROTEX APPROVED - LINER END LAP SEALANT
 4mm / 9mm * 3mm BUTYL TAPE
LOCATION
 CONTINUOUS RUN.
 25mm ABOVE FIXING LINE

N1000L+ / EQ EXTERNAL ROOF PROFILE
 GAUGE - 0.4mm
 COATING - PROTEX APPROVED
 POSITIONED OVER-OVER
 EQUAL LAP PROFILE

PROTEX APPROVED - ROOFLIGHT MAIN FIX
 STAINLESS STEEL SELF DRILLING & SELF TAPPING
 POPPY RED -PAINTED / MOULDED HEAD
 29mm Ø EDPM WASHER
PATTERN
 FIXED IN EVERY TROUGH

N1000R / EQ EXTERNAL ROOF PROFILE
 GAUGE - 0.7mm
 COATING - PROTEX APPROVED
 POSITIONED OVER-OVER
 EQUAL LAP PROFILE

PROTEX APPROVED - LINER END LAP SEALANT
 4mm / 9mm * 3mm BUTYL TAPE
LOCATION
 CONTINUOUS RUN.
 25mm ABOVE FIXING LINE

ALTERNATIVE END LAP DETAIL

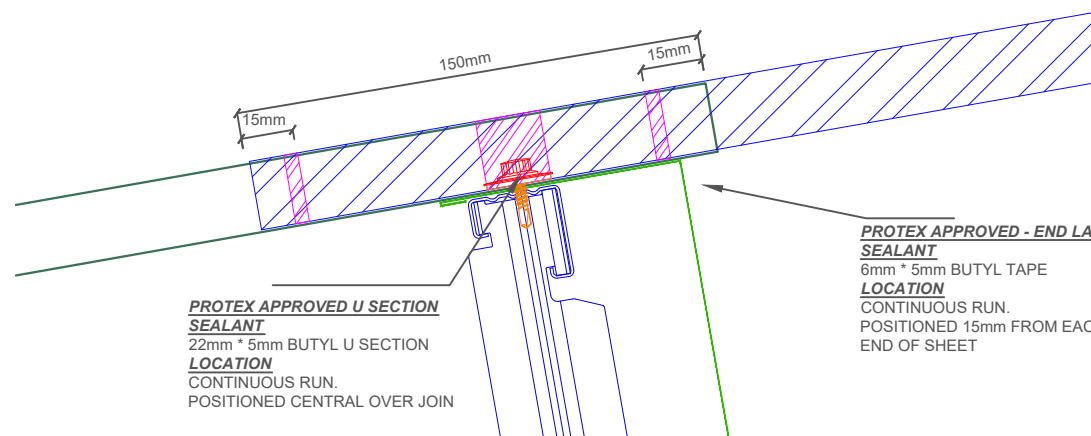

ROOFLIGHTS AND ROOF SAFETY

The Health and Safety Executive clearly state that those persons responsible for the design of a roof structure should consider carefully the potential to eliminate or reduce the hazard of using materials that are of a fragile nature. GRP rooflights provide an effective and long term means of compliance.
 ACR[M]001:2011 [4th Edition] Test For Non-Fragility of Profiled Sheeted Roofing Assemblies is a test of the completed roof assembly that defines the test procedure and minimum standard required to demonstrate and achieve non-fragility classification.

- INSTALLATION NOTES**
- FLASHING JOINTS SEALED WITH BUTYL
 - FLASHING JOINTS FIXED AT 100mm CENTRES (RIVET OR STITCH)
 - FLASHINGS FIXED AT 450mm CENTRES
 - BRACKET MUST BE POSITIONED WITHIN 100mm OF END OF BAR OR MALE END JOIN
 - NO IMPACT DRIVERS OR CLUTCHLESS DRILLS
 - NO CARBON FIXINGS

REV	DATE	DESCRIPTION

FirthSteels[®]
 Firth Steels Ltd, Calderbank, River Street, Brighouse, West Yorkshire HD6 1LU
 Technical@firth-steels.co.uk +44 1484 405940 Firth-steels.co.uk

SGS SGS SGS UKAS PLANETMARK

PROTEX[®]

UK CA LPCB UKAS

LPS 1181 Cert.LPCB ref. 1811a

This draft drawing has been supplied by Firth Steels Ltd for guidance purposes only and is provided free of charge. It represents a suggested typical detail and should not be assumed as suitable for any specific project or application. It is essential to read this in conjunction with the Protex System specification documents to ensure completeness of information.
 Please note, no responsibility is assumed for errors or misinterpretations resulting from the information contained within this drawing. Details depicted are for illustration purposes only, and no liability is accepted for their use. Firth Steels reserves the right to modify details without notice. This drawing is the property of Firth Steels Ltd, any reproduction without explicit written consent is prohibited.
 Firth Steels is committed to ongoing improvement. The details and data shared in this document are reflective of the current state as of the issue date. It is the duty of the recipients to ensure that the information in this document is still up-to-date at the time of its use.

Drawing Number
Protex-RS02-3 Rooflight Detail

Drawn by TO Checked by KP Date 24/09/2024

Project Title PRX-RS-02 Size A3 Revision A

<<< DO NOT SCALE FROM THIS DRAWING >>>

DIRECTION OF LAY



PROTEX APPROVED SPACER SYSTEM
 BRACKET DEPTH TO SUIT U-VALUE CALCULATIONS
 MINIMUM DEPTH 120mm
PATTERN
 MAX RAIL CENTRE'S 1800mm
 BRACKET POSITIONED TO BE POSITIONED EACH SIDE OF ROOFLIGHT
 BRACKET CENTRE'S TO SUIT LOADING CALCULATIONS
 BRACKET MUST BE PLACED WITHIN 100mm OF MALE END OF SPACER SYSTEM JOINT AND BAR END, JOINT MUST NOT BE PLACED WITHIN ROOFLIGHT

N1000R EXTERNAL ROOF PROFILE
 GAUGE - 0.7mm
 COATING - PROTEX APPROVED

PROTEX APPROVED - EXTERNAL MAIN FIXING
 STAINLESS STEEL SELF DRILLING & SELF TAPPING
 PAINTED / MOULDED HEAD
 19mm Ø EDPM WASHER
PATTERN
 SHEET ENDS - EVERY TROUGH - 5 NO. FIXINGS
 INTERMEDIATE SUPPORTS - ALTERNATE TROUGH - 3 NO. FIXINGS

PROTEX APPROVED - EXTERNAL ROOFLIGHT MAIN FIXING
 STAINLESS STEEL SELF DRILLING & SELF TAPPING
 POPPY RED PAINTED / MOULDED HEAD
 29mm Ø EDPM WASHER
PATTERN
 SHEET ENDS - EVERY TROUGH - 5 NO. FIXINGS
 INTERMEDIATE SUPPORTS - EVERY TROUGH - 5 NO. FIXINGS

PROTEX APPROVED ROOFLIGHT PROFILE - N1000R EQUAL LAP ROOFLIGHT
 PROTEX APPROVED SUPPLIER
 POSITIONED OVER - OVER (SYSTEM TO ACHIEVE CLASS B NON FRAGILITY)

PROTEX APPROVED - EXTERNAL STITCHER FIXING
 STAINLESS STEEL SELF DRILLING & SELF TAPPING
 POPPY RED PAINTED / MOULDED HEAD
 16mm Ø EDPM WASHER
PATTERN
 SIDE LAP - 300mm CENTRES

PROTEX APPROVED SIDE LAP SEALANT
 6mm * 5mm BUTYL TAPE
LOCATION
 POSITIONED WEATHER SIDE OF FIXING

PROTEX APPROVED - GLASS FIBRE INSULATION
 THICKNESS TO SUIT U-VALUE REQUIREMENT
 MINIMUM THICKNESS - 120mm
 FIRE CLASS A1 TO EN 13501-1
 MANUFACTURED IN ACCORDANCE WITH BS EN 13162
 (SUGGESTED THICKNESS TO BE >10% THAN SPACER SYSTEM DEPTH.)

BRACKET POSITIONED TO BE POSITIONED EACH SIDE OF ROOFLIGHT

PROTEX APPROVED - LINER MAIN FIXING
 STAINLESS STEEL SELF DRILLING & SELF TAPPING
 16mm Ø EDPM WASHER
PATTERN
 SHEET ENDS - EVERY TROUGH - 6 NO. FIXINGS
 INTERMEDIATE SUPPORTS - ALTERNATE TROUGH - 4 NO. FIXINGS

PROTEX APPROVED - SIDE FLASHINGS
 THICKNESS - 0.7mm
 COLOUR - BRIGHT WHITE LINER
 COATING - PROTEX APPROVED

PROTEX APPROVED ROOFLIGHT PROFILE - N1000L+ ROOFLIGHT
 PROTEX APPROVED SUPPLIER
 MINIMUM CLASS 1 TO BS476.
 MINIMUM CLASS B NON FRAGILITY
 POSITIONED OVER - OVER

PROTEX APPROVED - LINER MAIN FIXING
 STAINLESS STEEL SELF DRILLING & SELF TAPPING
 29mm Ø EDPM WASHER
PATTERN
 SHEET ENDS - EVERY TROUGH & INTERMEDIATES EVERY TROUGH - 6 NO. FIXINGS

PROTEX APPROVED - POLYCARBONATE INTERMEDIATE INSULATOR
 THICKNESS - 4mm/10mm/20mm
 SUBJECT TO REQUIREMENTS

PROTEX APPROVED - LINER SIDE LAP SEALANT
 50mm * 1mm BUTYL TAPE
LOCATION
 POSITIONED OVER POLYCARBONATE AND LINER PROFILE TO SECURE IN PLACE

PROTEX APPROVED - LINER SIDE LAP SEALANT
 50mm * 1mm BUTYL TAPE
LOCATION
 CONTINUOUS RUN.
 POSITIONED CENTRAL OVER JOIN

PROTEX APPROVED - BRACKET FIXING
 STAINLESS STEEL SELF DRILLING & SELF TAPPING
 16mm Ø EDPM WASHER
PATTERN
 AS PER LAYOUT CALCULATIONS

N1000L+ INTERNAL LINER PROFILE
 GAUGE - 0.4mm
 COATING - BRIGHT WHITE LINER LINER

PROTEX APPROVED - GLASS FIBRE INSULATION
 THICKNESS TO SUIT U-VALUE REQUIREMENT
 MINIMUM THICKNESS - 120mm
 FIRE CLASS A1 TO EN 13501-1
 MANUFACTURED IN ACCORDANCE WITH BS EN 13162
 (SUGGESTED THICKNESS TO BE >10% THAN SPACER SYSTEM DEPTH.)

ALTERNATIVE LAP DETAIL
 POSITIONED UNDER/OVER
 EQUAL N1000L+ ROOFLIGHT
 LAPLOCK FIXING USED ON UNDER SIDE

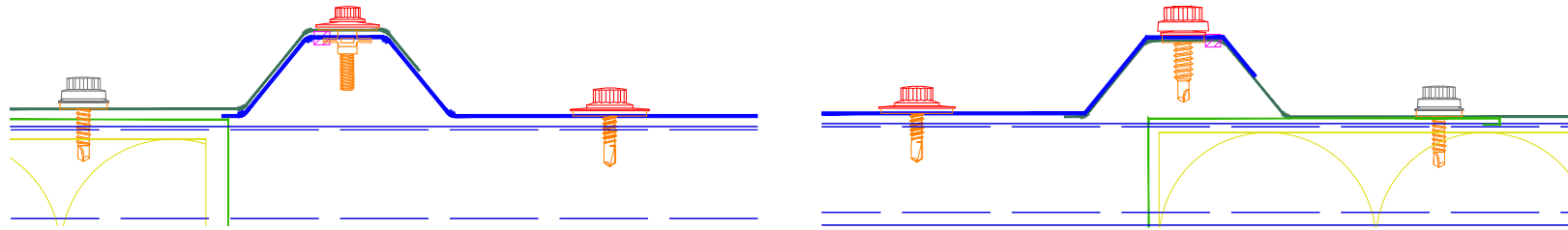

- INSTALLATION NOTES**
- FLASHING JOINTS SEALED WITH BUTYL
 - FLASHING JOINTS FIXED AT 100mm CENTRES (RIVET OR STITCH)
 - FLASHINGS FIXED AT 450mm CENTRES
 - BRACKET MUST BE POSITIONED WITHIN 100mm OF END OF BAR OR MALE END JOIN
 - NO IMPACT DRIVERS OR CLUTCHLESS DRILLS
 - NO CARBON FIXINGS

ROOFLIGHTS AND ROOF SAFETY

The Health and Safety Executive clearly state that those persons responsible for the design of a roof structure should consider carefully the potential to eliminate or reduce the hazard of using materials that are of a fragile nature. GRP rooflights provide an effective and long term means of compliance.
 ACR[M]001:2011 [4th Edition] Test For Non-Fragility of Profiled Sheeted Roofing Assemblies is a test of the completed roof assembly that defines the test procedure and minimum standard required to demonstrate and achieve non-fragility classification.

REV	DATE	DESCRIPTION

FirthSteels[®]
 Firth Steels Ltd, Calderbank, River Street, Brighouse, West Yorkshire HD6 1LU
 Technical@firth-steels.co.uk +44 1484 405940 firth-steels.co.uk

PROTEX[®]
 UKCA
 LPCB
 UKAS
 LPS 1181 CertLPCB ref: 1811a

This draft drawing has been supplied by Firth Steels Ltd for guidance purposes only and is provided free of charge. It represents a suggested typical detail and should not be assumed as suitable for any specific project or application. It is essential to read this in conjunction with the Protex System specification documents to ensure completeness of information.
 Please note, no responsibility is assumed for errors or misinterpretations resulting from the information contained within this drawing. Details depicted are for illustration purposes only, and no liability is accepted for their use. Firth Steels reserves the right to modify details without notice. This drawing is the property of Firth Steels Ltd, any reproduction without explicit written consent is prohibited.
 Firth Steels is committed to ongoing improvement. The details and data shared in this document are reflective of the current state as of the issue date. It is the duty of the recipients to ensure that the information in this document is still up-to-date at the time of its use.

Drawing Number
Protex-RS02-3.1 Rooflight Side Detail

Drawn by TO Checked by KP Date 24/09/2024

Project Title PRX-RS-02 Size A3 Revision A

<<< DO NOT SCALE FROM THIS DRAWING >>>

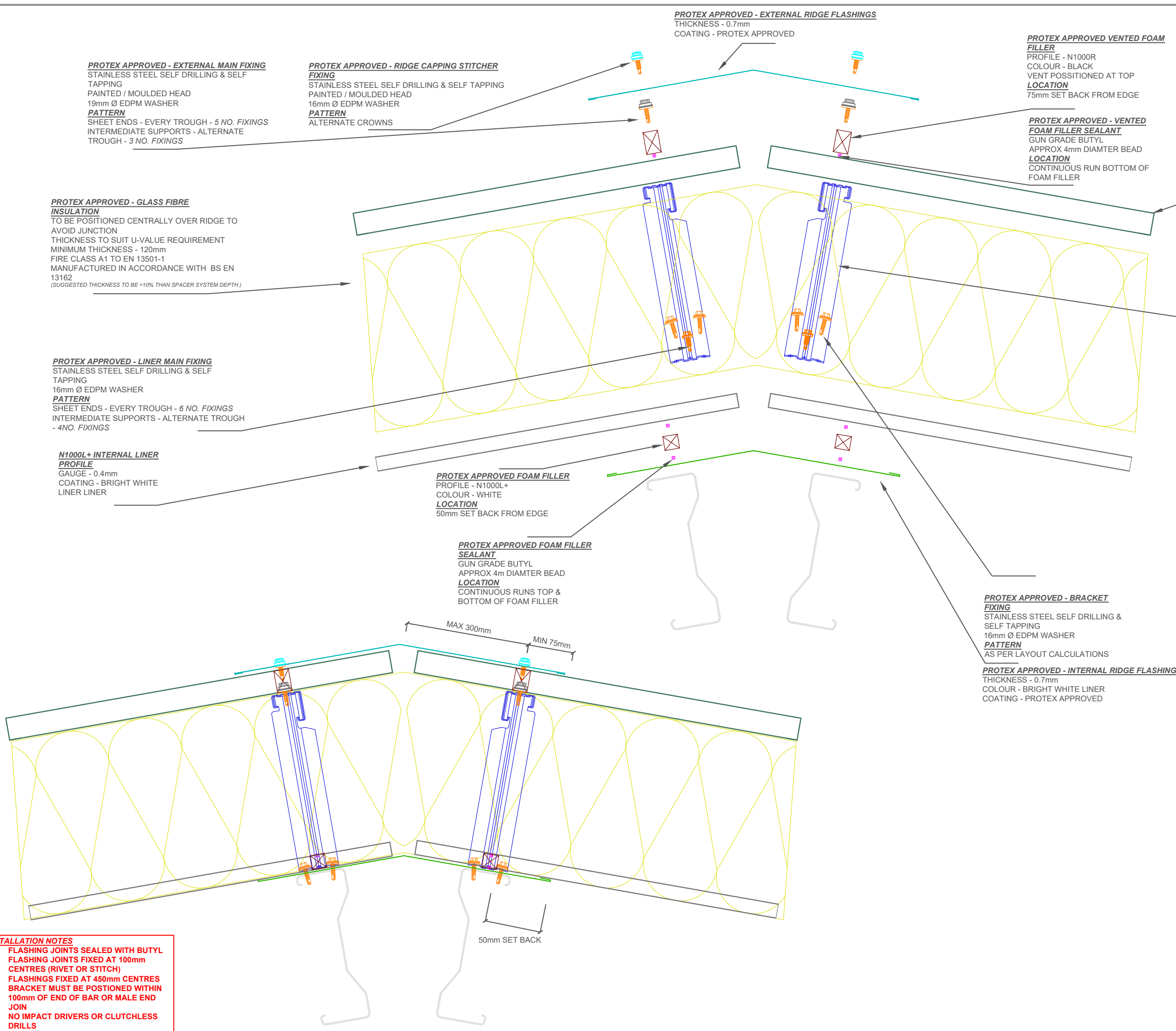

PROTEX APPROVED - EXTERNAL MAIN FIXING
 STAINLESS STEEL SELF DRILLING & SELF TAPPING
 PAINTED / MOULDED HEAD
 19mm Ø EDPM WASHER
PATTERN
 SHEET ENDS - EVERY TROUGH - 5 NO. FIXINGS
 INTERMEDIATE SUPPORTS - ALTERNATE TROUGH - 3 NO. FIXINGS

PROTEX APPROVED - RIDGE CAPPING STITCHER FIXING
 STAINLESS STEEL SELF DRILLING & SELF TAPPING
 PAINTED / MOULDED HEAD
 16mm Ø EDPM WASHER
PATTERN
 ALTERNATE CROWNS

PROTEX APPROVED - EXTERNAL RIDGE FLASHINGS
 THICKNESS - 0.7mm
 COATING - PROTEX APPROVED

PROTEX APPROVED VENTED FOAM FILLER
 PROFILE - N1000R
 COLOUR - BLACK
 VENT POSITIONED AT TOP
LOCATION
 75mm SET BACK FROM EDGE

PROTEX APPROVED - VENTED FOAM FILLER SEALANT
 GUN GRADE BUTYL
 APPROX 4mm DIAMETER BEAD
LOCATION
 CONTINUOUS RUN BOTTOM OF FOAM FILLER

N1000R EXTERNAL ROOF PROFILE
 GAUGE - 0.7mm
 COATING - PROTEX APPROVED

PROTEX APPROVED - SPACER SYSTEM
 BRACKET DEPTH TO SUIT U-VALUE CALCULATIONS
 MINIMUM DEPTH 120mm
PATTERN
 MAX RAIL CENTRE'S 1800mm
 MAX BRACKET CENTRE'S 1000mm
 BRACKET CENTRE'S TO SUIT LOADING CALCULATIONS
 BRACKET MUST BE PLACED WITHIN 100mm OF MALE END OF SPACER SYSTEM JOINT AND BAR END

PROTEX APPROVED - GLASS FIBRE INSULATION
 TO BE POSITIONED CENTRALLY OVER RIDGE TO AVOID JUNCTION
 THICKNESS TO SUIT U-VALUE REQUIREMENT
 MINIMUM THICKNESS - 120mm
 FIRE CLASS A1 TO EN 13501-1
 MANUFACTURED IN ACCORDANCE WITH BS EN 13162
 (SUGGESTED THICKNESS TO BE >10% THAN SPACER SYSTEM DEPTH)

PROTEX APPROVED - LINER MAIN FIXING
 STAINLESS STEEL SELF DRILLING & SELF TAPPING
 16mm Ø EDPM WASHER
PATTERN
 SHEET ENDS - EVERY TROUGH - 6 NO. FIXINGS
 INTERMEDIATE SUPPORTS - ALTERNATE TROUGH - 4 NO. FIXINGS

N1000L+ INTERNAL LINER PROFILE
 GAUGE - 0.4mm
 COATING - BRIGHT WHITE
 LINER LINER

PROTEX APPROVED FOAM FILLER
 PROFILE - N1000L+
 COLOUR - WHITE
LOCATION
 50mm SET BACK FROM EDGE

PROTEX APPROVED FOAM FILLER SEALANT
 GUN GRADE BUTYL
 APPROX 4mm DIAMETER BEAD
LOCATION
 CONTINUOUS RUNS TOP & BOTTOM OF FOAM FILLER

PROTEX APPROVED - BRACKET FIXING
 STAINLESS STEEL SELF DRILLING & SELF TAPPING
 16mm Ø EDPM WASHER
PATTERN
 AS PER LAYOUT CALCULATIONS

PROTEX APPROVED - INTERNAL RIDGE FLASHINGS
 THICKNESS - 0.7mm
 COLOUR - BRIGHT WHITE LINER
 COATING - PROTEX APPROVED

MAX 300mm
 MIN 75mm

50mm SET BACK

- INSTALLATION NOTES**
- FLASHING JOINTS SEALED WITH BUTYL
 - FLASHING JOINTS FIXED AT 100mm CENTRES (RIVET OR STITCH)
 - FLASHINGS FIXED AT 450mm CENTRES
 - BRACKET MUST BE POSITIONED WITHIN 100mm OF END OF BAR OR MALE END JOINT
 - NO IMPACT DRIVERS OR CLUTCHLESS DRILLS
 - NO CARBON FIXINGS

REV	DATE	DESCRIPTION

Firth Steels
 Firth Steels Ltd, Calderbank, River Street, Brighouse, West Yorkshire HD6 1LU
 Technical@firth-steels.co.uk +44 1484 405940 Firth-steels.co.uk

SGS SGS SGS UKAS
 PlanetMark

PROTEX
 UKCA
 LPCB
 UKAS
 LPS 1181 Cert/LPCB ref. 1611a

This draft drawing has been supplied by Firth Steels Ltd for guidance purposes only and is provided free of charge. It represents a suggested typical detail and should not be assumed as suitable for any specific project or application. It is essential to read this in conjunction with the Protex System specification documents to ensure completeness of information.
 Please note, no responsibility is assumed for errors or misinterpretations resulting from the information contained within this drawing. Details depicted are for illustration purposes only, and no liability is accepted for their use. Firth Steels reserves the right to modify details without notice. This drawing is the property of Firth Steels Ltd, any reproduction without explicit written consent is prohibited.
 Firth Steels is committed to ongoing improvement. The details and data shared in this document are reflective of the current state as of the issue date. It is the duty of the recipients to ensure that the information in this document is still up-to-date at the time of its use.

Drawing Number
Protex-RS02-4 Standard Ridge Flashing

Drawn by TO Checked by KP Date 24/09/2024

Project Title PRX-RS-02 Size A3 Revision A

<<< DO NOT SCALE FROM THIS DRAWING >>>

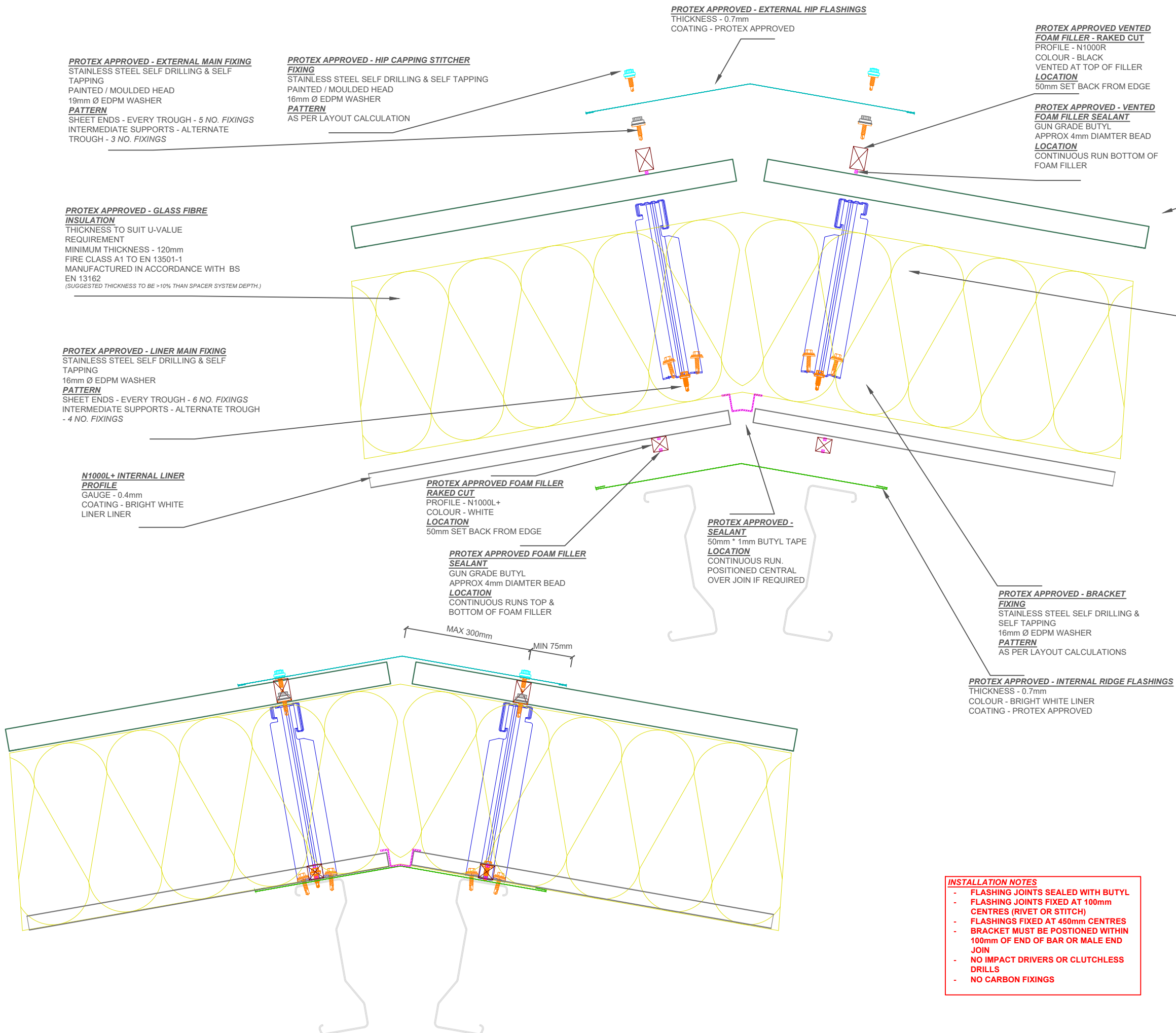

PROTEX APPROVED - EXTERNAL MAIN FIXING
 STAINLESS STEEL SELF DRILLING & SELF TAPPING
 PAINTED / MOULDED HEAD
 19mm Ø EDPM WASHER
PATTERN
 SHEET ENDS - EVERY TROUGH - 5 NO. FIXINGS
 INTERMEDIATE SUPPORTS - ALTERNATE TROUGH - 3 NO. FIXINGS

PROTEX APPROVED - HIP CAPPING STITCHER FIXING
 STAINLESS STEEL SELF DRILLING & SELF TAPPING
 PAINTED / MOULDED HEAD
 16mm Ø EDPM WASHER
PATTERN
 AS PER LAYOUT CALCULATION

PROTEX APPROVED - EXTERNAL HIP FLASHINGS
 THICKNESS - 0.7mm
 COATING - PROTEX APPROVED

PROTEX APPROVED VENTED FOAM FILLER - RAKED CUT
 PROFILE - N1000R
 COLOUR - BLACK
 VENTED AT TOP OF FILLER
LOCATION
 50mm SET BACK FROM EDGE

PROTEX APPROVED - VENTED FOAM FILLER SEALANT
 GUN GRADE BUTYL
 APPROX 4mm DIAMTER BEAD
LOCATION
 CONTINUOUS RUN BOTTOM OF FOAM FILLER

N1000R EXTERNAL ROOF PROFILE
 GAUGE - 0.7mm
 COATING - PROTEX APPROVED

PROTEX APPROVED - GLASS FIBRE INSULATION
 THICKNESS TO SUIT U-VALUE REQUIREMENT
 MINIMUM THICKNESS - 120mm
 FIRE CLASS A1 TO EN 13501-1
 MANUFACTURED IN ACCORDANCE WITH BS EN 13162
 (SUGGESTED THICKNESS TO BE >10% THAN SPACER SYSTEM DEPTH.)

PROTEX APPROVED - LINER MAIN FIXING
 STAINLESS STEEL SELF DRILLING & SELF TAPPING
 16mm Ø EDPM WASHER
PATTERN
 SHEET ENDS - EVERY TROUGH - 6 NO. FIXINGS
 INTERMEDIATE SUPPORTS - ALTERNATE TROUGH - 4 NO. FIXINGS

N1000L+ INTERNAL LINER PROFILE
 GAUGE - 0.4mm
 COATING - BRIGHT WHITE LINER LINER

PROTEX APPROVED FOAM FILLER RAKED CUT
 PROFILE - N1000L+
 COLOUR - WHITE
LOCATION
 50mm SET BACK FROM EDGE

PROTEX APPROVED FOAM FILLER SEALANT
 GUN GRADE BUTYL
 APPROX 4mm DIAMTER BEAD
LOCATION
 CONTINUOUS RUNS TOP & BOTTOM OF FOAM FILLER

PROTEX APPROVED - SEALANT
 50mm * 1mm BUTYL TAPE
LOCATION
 CONTINUOUS RUN. POSITIONED CENTRAL OVER JOIN IF REQUIRED

PROTEX APPROVED - BRACKET FIXING
 STAINLESS STEEL SELF DRILLING & SELF TAPPING
 16mm Ø EDPM WASHER
PATTERN
 AS PER LAYOUT CALCULATIONS

PROTEX APPROVED - INTERNAL RIDGE FLASHINGS
 THICKNESS - 0.7mm
 COLOUR - BRIGHT WHITE LINER
 COATING - PROTEX APPROVED

PROTEX APPROVED - SPACER SYSTEM
 BRACKET DEPTH TO SUIT U-VALUE CALCULATIONS
 MINIMUM DEPTH 120mm
PATTERN
 MAX RAIL CENTRE'S 1800mm
 MAX BRACKET CENTRE'S 1000mm
 BRACKET CENTRE'S TO SUIT LOADING CALCULATIONS
 BRACKET MUST PLACED WITHIN 100mm OF MALE END OF SPACER SYSTEM JOINT AND BAR END

MAX 300mm
 MIN 75mm

- INSTALLATION NOTES**
- FLASHING JOINTS SEALED WITH BUTYL
 - FLASHING JOINTS FIXED AT 100mm CENTRES (RIVET OR STITCH)
 - FLASHINGS FIXED AT 450mm CENTRES
 - BRACKET MUST BE POSITIONED WITHIN 100mm OF END OF BAR OR MALE END JOIN
 - NO IMPACT DRIVERS OR CLUTCHLESS DRILLS
 - NO CARBON FIXINGS

REV	DATE	DESCRIPTION

FirthSteels
 Firth Steels Ltd, Calderbank, River Street, Brighouse, West Yorkshire HD6 1LU
 Technical@firth-steels.co.uk +44 1484 405940 Firth-steels.co.uk

SGS SGS SGS UKAS
 PlanetMark

PROTEX
 UKCA
 LPCB
 UKAS
 LPS 1181 Cert.LPCB ref. 1611a

This draft drawing has been supplied by Firth Steels Ltd for guidance purposes only and is provided free of charge. It represents a suggested typical detail and should not be assumed as suitable for any specific project or application. It is essential to read this in conjunction with the Protex System specification documents to ensure completeness of information.
 Please note, no responsibility is assumed for errors or misinterpretations resulting from the information contained within this drawing. Details depicted are for illustration purposes only, and no liability is accepted for their use. Firth Steels reserves the right to modify details without notice. This drawing is the property of Firth Steels Ltd, any reproduction without explicit written consent is prohibited.
 Firth Steels is committed to ongoing improvement. The details and data shared in this document are reflective of the current state as of the issue date. It is the duty of the recipients to ensure that the information in this document is still up-to-date at the time of its use.

Drawing Number
Protex-RS02-5 Hip Ridge

Drawn by TO Checked by KP Date 24/09/2024

Project Title PRX-RS-02 Size A3 Revision A

<<< DO NOT SCALE FROM THIS DRAWING >>>

PROTEX APPROVED - SPACER SYSTEM
 BRACKET DEPTH TO SUIT U-VALUE CALCULATIONS
 MINIMUM DEPTH 120mm
PATTERN
 MAX RAIL CENTRE'S 1800mm
 MAX BRACKET CENTRE'S 1000mm
 BRACKET CENTRE'S TO SUIT LOADING
 CALCULATIONS
 BRACKET MUST PLACED WITHIN 100mm OF MALE
 END OF SPACER SYSTEM JOINT
 BRACKET MUST BE 100mm WITHIN END OF BAR

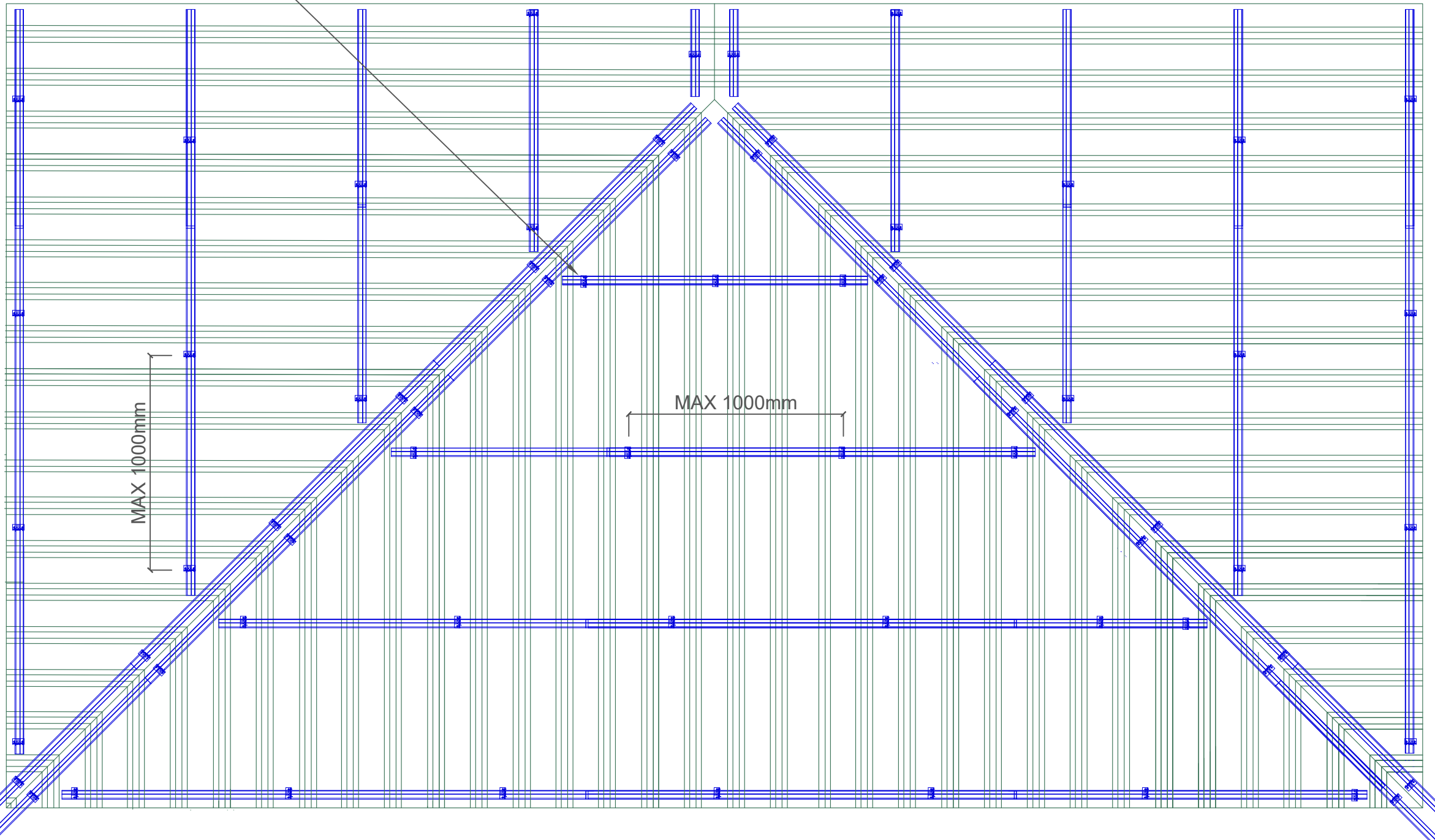

- INSTALLATION NOTES**
- FLASHING JOINTS SEALED WITH BUTYL
 - FLASHING JOINTS FIXED AT 100mm CENTRES (RIVET OR STITCH)
 - FLASHINGS FIXED AT 450mm CENTRES
 - BRACKET MUST BE POSITIONED WITHIN 100mm OF END OF BAR OR MALE END JOIN
 - NO IMPACT DRIVERS OR CLUTCHLESS DRILLS
 - NO CARBON FIXINGS

REV	DATE	DESCRIPTION



Firth Steels Ltd, Calderbank, River Street, Brighouse, West Yorkshire HD6 1LU
 Technical@firth-steels.co.uk +44 1484 405940 Firth-steels.co.uk







LPS 1181 Cert/LPCB ref. 1811a

This draft drawing has been supplied by Firth Steels Ltd for guidance purposes only and is provided free of charge. It represents a suggested typical detail and should not be assumed as suitable for any specific project or application. It is essential to read this in conjunction with the Protex System specification documents to ensure completeness of information.
 Please note, no responsibility is assumed for errors or misinterpretations resulting from the information contained within this drawing. Details depicted are for illustration purposes only, and no liability is accepted for their use. Firth Steels reserves the right to modify details without notice. This drawing is the property of Firth Steels Ltd, any reproduction without explicit written consent is prohibited.
 Firth Steels is committed to ongoing improvement. The details and data shared in this document are reflective of the current state as of the issue date. It is the duty of the recipients to ensure that the information in this document is still up-to-date at the time of its use.

Drawing Number
Protex-RS02-5 Hip Ridge Fixing detail

Drawn by TO	Checked by KP	Date 24/09/2024
----------------	------------------	--------------------

Project Title PRX-RS-02	Size A3	Revision A
----------------------------	------------	---------------

<<< DO NOT SCALE FROM THIS DRAWING >>>

PROTEX APPROVED - EXTERNAL MAIN FIXING
 STAINLESS STEEL SELF DRILLING & SELF TAPPING
 PAINTED / MOULDED HEAD
 19mm Ø EDPM WASHER
PATTERN
 SHEET END LAPS - EVERY TROUGH -
 5 NO. FIXINGS

PROTEX APPROVED - LINER MAIN FIXING
 STAINLESS STEEL SELF DRILLING & SELF TAPPING
 16mm Ø EDPM WASHER
PATTERN
 SHEET ENDS - EVERY TROUGH - 6 NO. FIXINGS
 INTERMEDIATE SUPPORTS - ALTERNATE TROUGH -
 4 NO. FIXINGS

PROTEX APPROVED - GLASS FIBRE INSULATION
 THICKNESS TO SUIT U-VALUE REQUIREMENT
 MINIMUM THICKNESS - 120mm
 FIRE CLASS A1 TO EN 13501-1
 MANUFACTURED IN ACCORDANCE WITH BS EN 13162
 (SUGGESTED THICKNESS TO BE >10% THAN SPACER SYSTEM DEPTH.)

N1000L+ INTERNAL LINER
PROFILE
 GAUGE - 0.4mm
 COATING - BRIGHT WHITE LINER LINER

PROTEX APPROVED - EXTERNAL STITCHER FIXING
 STAINLESS STEEL SELF DRILLING & SELF TAPPING
 PAINTED / MOULDED HEAD
 16mm Ø EDPM WASHER
PATTERN
 SIDE LAP - 450mm CENTRES
 50mm FROM SHEET END

PROTEX APPROVED - EXTERNAL CURVED RIDGE
 THICKNESS - 0.7mm
 COATING - PROTEX APPROVED
 MIN PITCH- 4°

PROTEX APPROVED END LAP SEALANT
 6mm * 5mm BUTYL TAPE
LOCATION
 15mm FROM END LAPS

N1000R EXTERNAL PROFILE
 GAUGE - 0.7mm
 COATING - PROTEX APPROVED

PROTEX APPROVED SPACER SYSTEM
 BRACKET DEPTH TO SUIT U-VALUE CALCULATIONS
 MINIMUM DEPTH 120mm
PATTERN
 MAX RAIL CENTRE'S 1800mm
 MAX BRACKET CENTRE'S 1000mm
 BRACKET CENTRE'S TO SUIT LOADING CALCULATIONS
 BRACKET MUST BE PLACED WITHIN 100mm OF MALE END OF SPACER SYSTEM JOINT AND BAR END

PROTEX APPROVED - BRACKET FIXING
 STAINLESS STEEL SELF DRILLING & SELF TAPPING
 16mm Ø EDPM WASHER
PATTERN
 AS PER LAYOUT CALCULATIONS

PROTEX APPROVED FOAM FILLER SEALANT
 GUN GRADE BUTYL
 APPROX 4m DIAMETER BEAD
LOCATION
 CONTINUOUS RUNS TOP & BOTTOM OF FOAM FILLER

PROTEX APPROVED FOAM FILLER
 PROFILE - N1000L+
 COLOUR - WHITE
LOCATION
 50mm SET BACK FROM EDGE

PROTEX APPROVED - INTERNAL RIDGE FLASHINGS
 THICKNESS - 0.7mm
 COLOUR - BRIGHT WHITE LINER
 COATING - PROTEX APPROVED

REV	DATE	DESCRIPTION

FirthSteels[®]

Firth Steels Ltd, Calderbank, River Street, Brighouse, West Yorkshire HD6 1LU
 Technical@firth-steels.co.uk +44 1484 405940 Firth-steels.co.uk



PROTEX[®]

UK CA



LPS 1181 Cert/LPCB ref. 1611a

This draft drawing has been supplied by Firth Steels Ltd for guidance purposes only and is provided free of charge. It represents a suggested typical detail and should not be assumed as suitable for any specific project or application. It is essential to read this in conjunction with the Protex System specification documents to ensure completeness of information.

Please note, no responsibility is assumed for errors or misinterpretations resulting from the information contained within this drawing. Details depicted are for illustration purposes only, and no liability is accepted for their use. Firth Steels reserves the right to modify details without notice. This drawing is the property of Firth Steels Ltd, any reproduction without explicit written consent is prohibited.

Firth Steels is committed to ongoing improvement. The details and data shared in this document are reflective of the current state as of the issue date. It is the duty of the recipients to ensure that the information in this document is still up-to-date at the time of its use.

Drawing Number
Protex-RS02-6 Cranked Ridge

Drawn by TO	Checked by KP	Date 24/09/2024
-----------------------	-------------------------	---------------------------

Project Title PRX-RS-02	Size A3	Revision A
-----------------------------------	-------------------	----------------------

<<< DO NOT SCALE FROM THIS DRAWING >>>

- INSTALLATION NOTES**
- FLASHING JOINTS SEALED WITH BUTYL
 - FLASHING JOINTS FIXED AT 100mm CENTRES (RIVET OR STITCH)
 - FLASHINGS FIXED AT 450mm CENTRES
 - BRACKET MUST BE POSITIONED WITHIN 100mm OF END OF BAR OR MALE END JOIN
 - NO IMPACT DRIVERS OR CLUTCHLESS DRILLS
 - NO CARBON FIXINGS

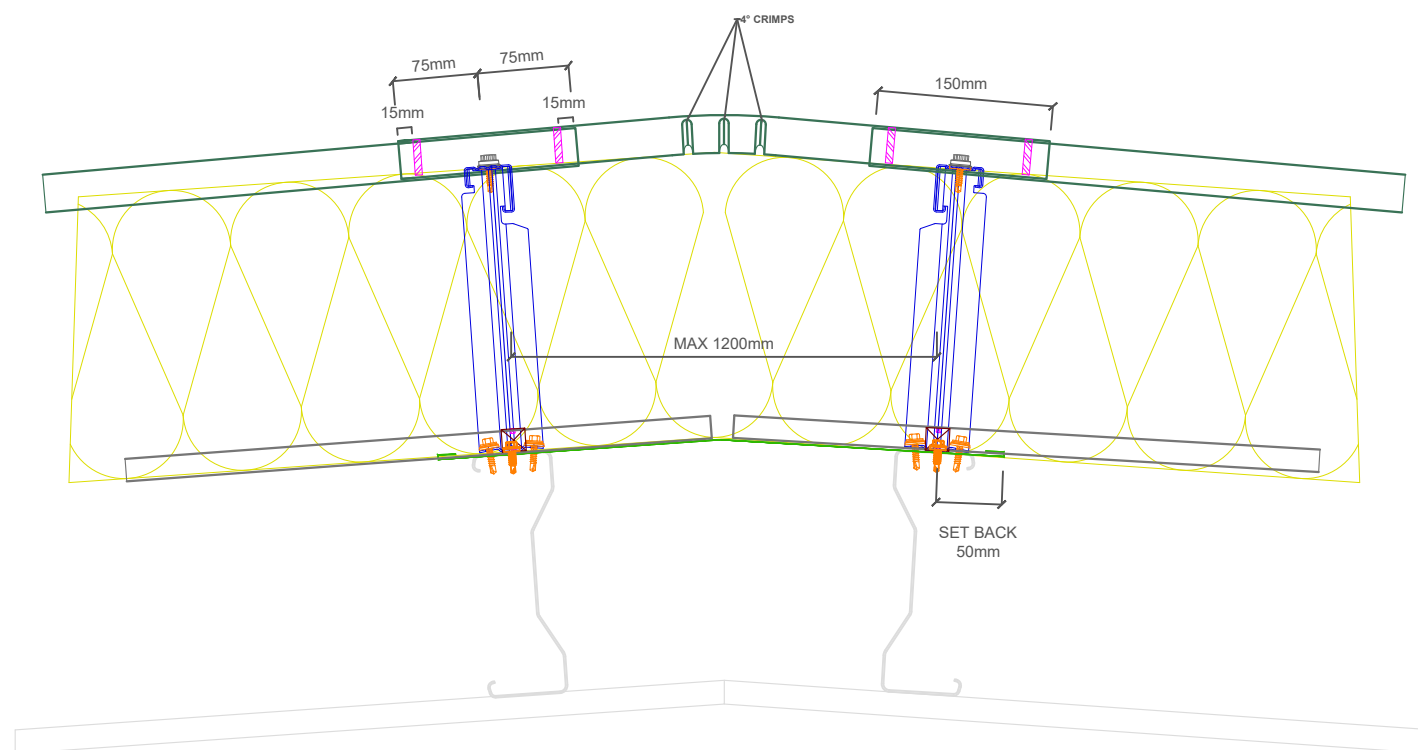

PROTEX APPROVED - EXTERNAL MAIN FIXING
 STAINLESS STEEL SELF DRILLING & SELF TAPPING
 PAINTED / MOULDED HEAD
 19mm Ø EDPM WASHER
PATTERN
 SHEET ENDS - EVERY TROUGH - 5 NO. FIXINGS
 INTERMEDIATE SUPPORTS - ALTERNATE TROUGH - 3 NO. FIXINGS

PROTEX APPROVED - RIDGE CAPPING STITCHER FIXING
 STAINLESS STEEL SELF DRILLING & SELF TAPPING
 PAINTED / MOULDED HEAD
 16mm Ø EDPM WASHER
PATTERN
 ALTERNATE CROWNS

PROTEX APPROVED - EXTERNAL RIDGE FLASHINGS
 THICKNESS - 0.7mm
 COATING - PROTEX APPROVED

PROTEX APPROVED VENTED FOAM FILLER
 PROFILE - N1000R
 COLOUR - BLACK
 VENT POSITIONED AT TOP
LOCATION
 75mm SET BACK FROM EDGE

N1000R EXTERNAL PROFILE
 GAUGE - 0.7mm
 COATING - PROTEX APPROVED

PROTEX APPROVED SPACER SYSTEM
 CALCULATIONS
 BRACKET DEPTH TO SUIT U-VALUE
 MINIMUM DEPTH 120mm
PATTERN
 MAX RAIL CENTRE'S 1800mm
 MAX BRACKET CENTRE'S 1000mm
 BRACKET CENTRE'S TO SUIT LOADING CALCULATIONS
 BRACKET MUST BE PLACED WITHIN 100mm OF MALE END OF SPACER SYSTEM JOINT AND BAR END

PROTEX APPROVED - VENTED FOAM FILLER SEALANT
 GUN GRADE BUTYL
 APPROX 4mm DIAMETER BEAD
LOCATION
 CONTINUOUS RUN BOTTOM OF FOAM FILLER

PROTEX APPROVED - GLASS FIBRE INSULATION
 THICKNESS TO SUIT U-VALUE REQUIREMENT
 MINIMUM THICKNESS - 120mm
 FIRE CLASS A1 TO EN 13501-1
 MANUFACTURED IN ACCORDANCE WITH BS EN 13162
 (SUGGESTED THICKNESS TO BE >10% THAN SPACER SYSTEM DEPTH.)

PROTEX APPROVED - LINER MAIN FIXING
 STAINLESS STEEL SELF DRILLING & SELF TAPPING
 16mm Ø EDPM WASHER
PATTERN
 SHEET ENDS - EVERY TROUGH - 6 NO. FIXINGS
 INTERMEDIATE SUPPORTS - ALTERNATE TROUGH - 4 NO. FIXINGS

PROTEX APPROVED - BRACKET FIXING
 STAINLESS STEEL SELF DRILLING & SELF TAPPING
 16mm Ø EDPM WASHER
PATTERN
 AS PER LAYOUT CALCULATIONS

PROTEX APPROVED - LINER END LAP SEALANT
 4mm / 9mm * 3mm BUTYL TAPE
LOCATION
 CONTINUOUS RUN.
 POSITIONED 25mm FROM END

PROTEX APPROVED - N1000L+ INTERNAL CURVED RIDGE
 THICKNESS - 0.4mm
 COLOUR - BRIGHT WHITE LINER
 MIN PITCH - 4°

REV	DATE	DESCRIPTION

FirthSteels[®]
 Firth Steels Ltd, Calderbank, River Street, Brighouse, West Yorkshire HD6 1LU
 Technical@firth-steels.co.uk +44 1484 405940 Firth-steels.co.uk



PROTEX[®]



This draft drawing has been supplied by Firth Steels Ltd for guidance purposes only and is provided free of charge. It represents a suggested typical detail and should not be assumed as suitable for any specific project or application. It is essential to read this in conjunction with the Protex System specification documents to ensure completeness of information.
 Please note, no responsibility is assumed for errors or misinterpretations resulting from the information contained within this drawing. Details depicted are for illustration purposes only, and no liability is accepted for their use. Firth Steels reserves the right to modify details without notice. This drawing is the property of Firth Steels Ltd, any reproduction without explicit written consent is prohibited.
 Firth Steels is committed to ongoing improvement. The details and data shared in this document are reflective of the current state as of the issue date. It is the duty of the recipients to ensure that the information in this document is still up-to-date at the time of its use.

Drawing Number
Protex-RS02-6.1 Cranked Ridge

Drawn by TO Checked by KP Date 24/09/2024

Project Title PRX-RS-02 Size A3 Revision A

<<< DO NOT SCALE FROM THIS DRAWING >>>

INSTALLATION NOTES

- FLASHING JOINTS SEALED WITH BUTYL
- FLASHING JOINTS FIXED AT 100mm CENTRES (RIVET OR STITCH)
- FLASHINGS FIXED AT 450mm CENTRES
- BRACKET MUST BE POSITIONED WITHIN 100mm OF END OF BAR OR MALE END JOIN
- NO IMPACT DRIVERS OR CLUTCHLESS DRILLS
- NO CARBON FIXINGS

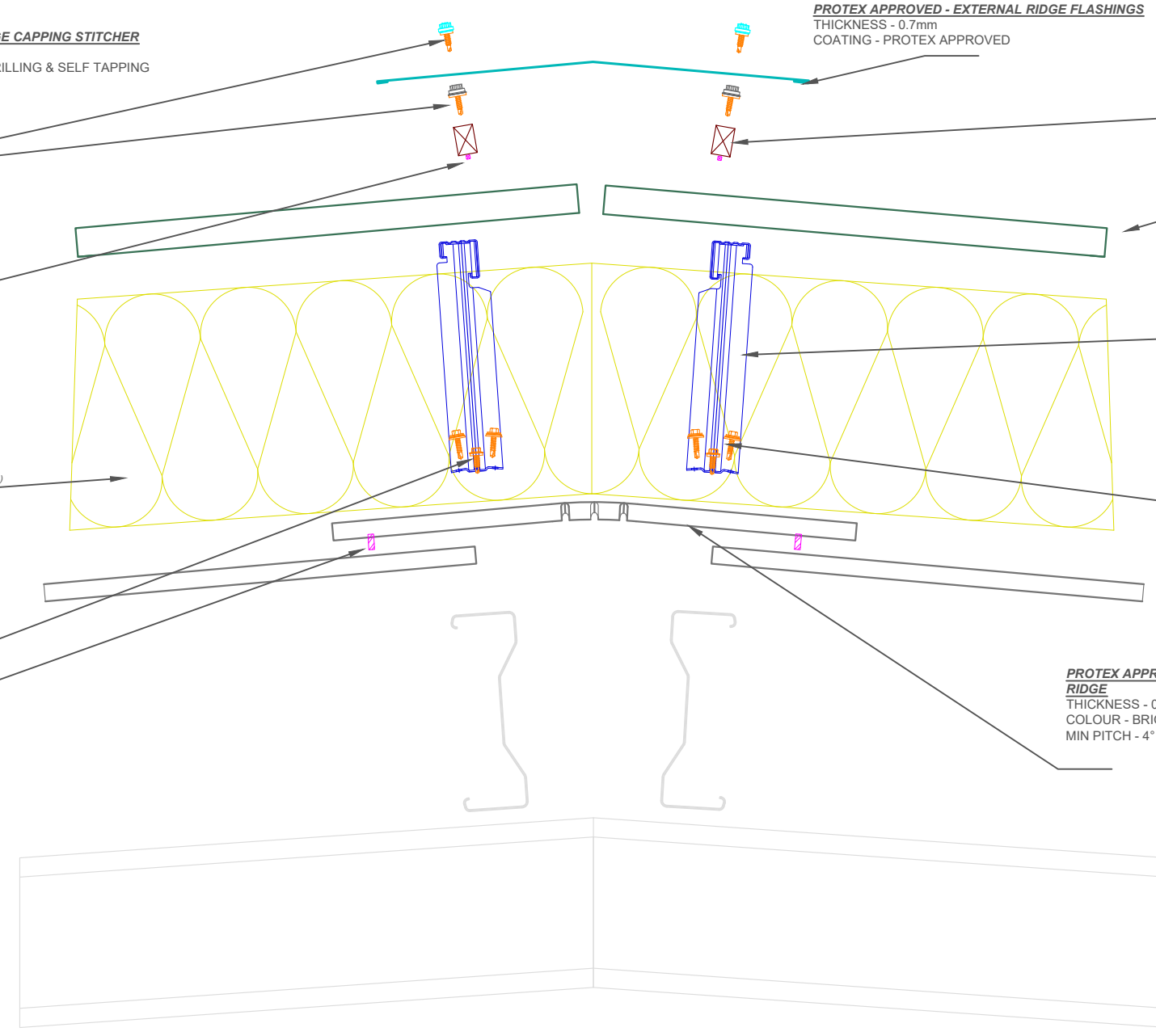
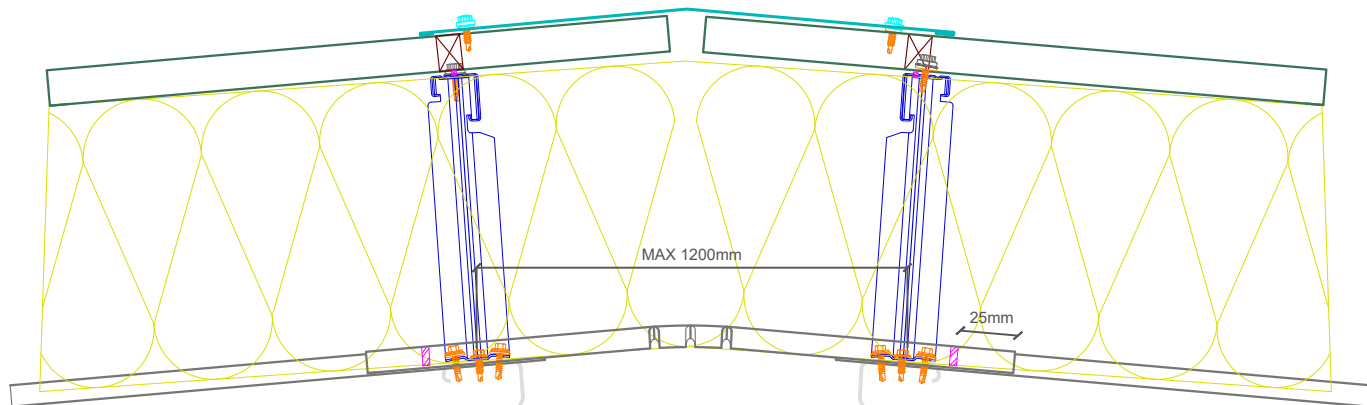

PROTEX APPROVED - EXTERNAL MAIN FIXING
 STAINLESS STEEL SELF DRILLING & SELF TAPPING
 PAINTED / MOULDED HEAD
 19mm Ø EDPM WASHER
PATTERN
 SHEET ENDS - EVERY TROUGH - 5 NO. FIXINGS
 INTERMEDIATE SUPPORTS - ALTERNATE TROUGH - 3 NO. FIXINGS

PROTEX APPROVED - EXTERNAL STITCHER FIXING
 STAINLESS STEEL SELF DRILLING & SELF TAPPING
 PAINTED / MOULDED HEAD
 16mm Ø EDPM WASHER
PATTERN
 SIDE LAP - 450mm CENTRES
 50mm FROM SHEET END

PROTEX APPROVED - EXTERNAL CURVED RIDGE
 PROFILE - N1000R
 THICKNESS - 0.7mm
 COATING - PROTEX APPROVED
 MIN PITCH - 4°

PROTEX APPROVED END LAP SEALANT
 6mm * 5mm BUTYL TAPE
LOCATION
 15mm FROM END LAPS

N1000R EXTERNAL PROFILE
 GAUGE - 0.7mm
 COATING - PROTEX APPROVED

PROTEX APPROVED SPACER SYSTEM
 BRACKET DEPTH TO SUIT U-VALUE CALCULATIONS
 MINIMUM DEPTH 120mm
PATTERN
 MAX RAIL CENTRE'S 1800mm
 MAX BRACKET CENTRE'S 1000mm
 BRACKET CENTRE'S TO SUIT LOADING CALCULATIONS
 BRACKET MUST BE PLACED WITHIN 100mm OF MALE END OF SPACER SYSTEM JOINT AND BAR END

PROTEX APPROVED - GLASS FIBRE INSULATION
 THICKNESS TO SUIT U-VALUE REQUIREMENT
 MINIMUM THICKNESS - 120mm
 FIRE CLASS A1 TO EN 13501-1
 MANUFACTURED IN ACCORDANCE WITH BS EN 13162
 (SUGGESTED THICKNESS TO BE >10% THAN SPACER SYSTEM DEPTH.)

PROTEX APPROVED - BRACKET FIXING
 STAINLESS STEEL SELF DRILLING & SELF TAPPING
 16mm Ø EDPM WASHER
PATTERN
 AS PER LAYOUT CALCULATIONS

PROTEX APPROVED - LINER MAIN FIXING
 STAINLESS STEEL SELF DRILLING & SELF TAPPING
 16mm Ø EDPM WASHER
PATTERN
 SHEET ENDS - EVERY TROUGH - 6 NO. FIXINGS
 INTERMEDIATE SUPPORTS - ALTERNATE TROUGH - 4 NO. FIXINGS

PROTEX APPROVED - INTERNAL CURVED RIDGE
 PROFILE - N1000L+
 THICKNESS - 0.4mm
 COLOUR - BRIGHT WHITE LINER
 MIN PITCH - 4°

PROTEX APPROVED - LINER END LAP SEALANT
 4mm / 9mm * 3mm BUTYL TAPE
LOCATION
 CONTINUOUS RUN.
 POSITIONED 25mm FROM END

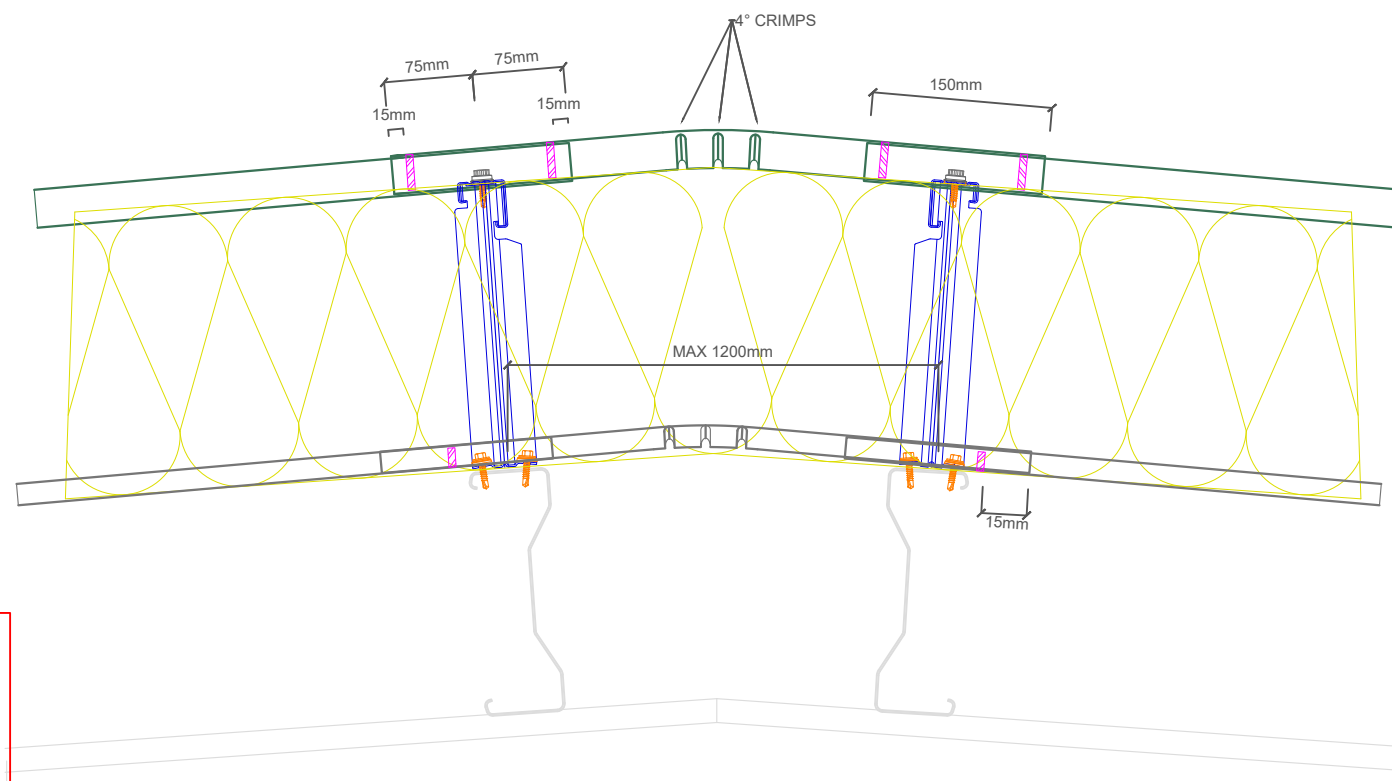

INSTALLATION NOTES

- FLASHING JOINTS SEALED WITH BUTYL
- FLASHING JOINTS FIXED AT 100mm CENTRES (RIVET OR STITCH)
- FLASHINGS FIXED AT 450mm CENTRES
- BRACKET MUST BE POSITIONED WITHIN 100mm OF END OF BAR OR MALE END JOINT
- NO IMPACT DRIVERS OR CLUTCHLESS DRILLS
- NO CARBON FIXINGS

REV	DATE	DESCRIPTION

FirthSteels[®]
 Firth Steels Ltd, Calderbank, River Street, Brighouse, West Yorkshire HD6 1LU
 Technical@firth-steels.co.uk +44 1484 405940 Firth-steels.co.uk



PROTEX[®]



This draft drawing has been supplied by Firth Steels Ltd for guidance purposes only and is provided free of charge. It represents a suggested typical detail and should not be assumed as suitable for any specific project or application. It is essential to read this in conjunction with the Protex System specification documents to ensure completeness of information.
 Please note, no responsibility is assumed for errors or misinterpretations resulting from the information contained within this drawing. Details depicted are for illustration purposes only, and no liability is accepted for their use. Firth Steels reserves the right to modify details without notice. This drawing is the property of Firth Steels Ltd, any reproduction without explicit written consent is prohibited.
 Firth Steels is committed to ongoing improvement. The details and data shared in this document are reflective of the current state as of the issue date. It is the duty of the recipients to ensure that the information in this document is still up-to-date at the time of its use.

Drawing Number
Protex-RS02-6.2 Cranked Liner Ridge

Drawn by TO Checked by KP Date 24/09/2024

Project Title PRX-RS-02 Size A3 Revision A

<<< DO NOT SCALE FROM THIS DRAWING >>>

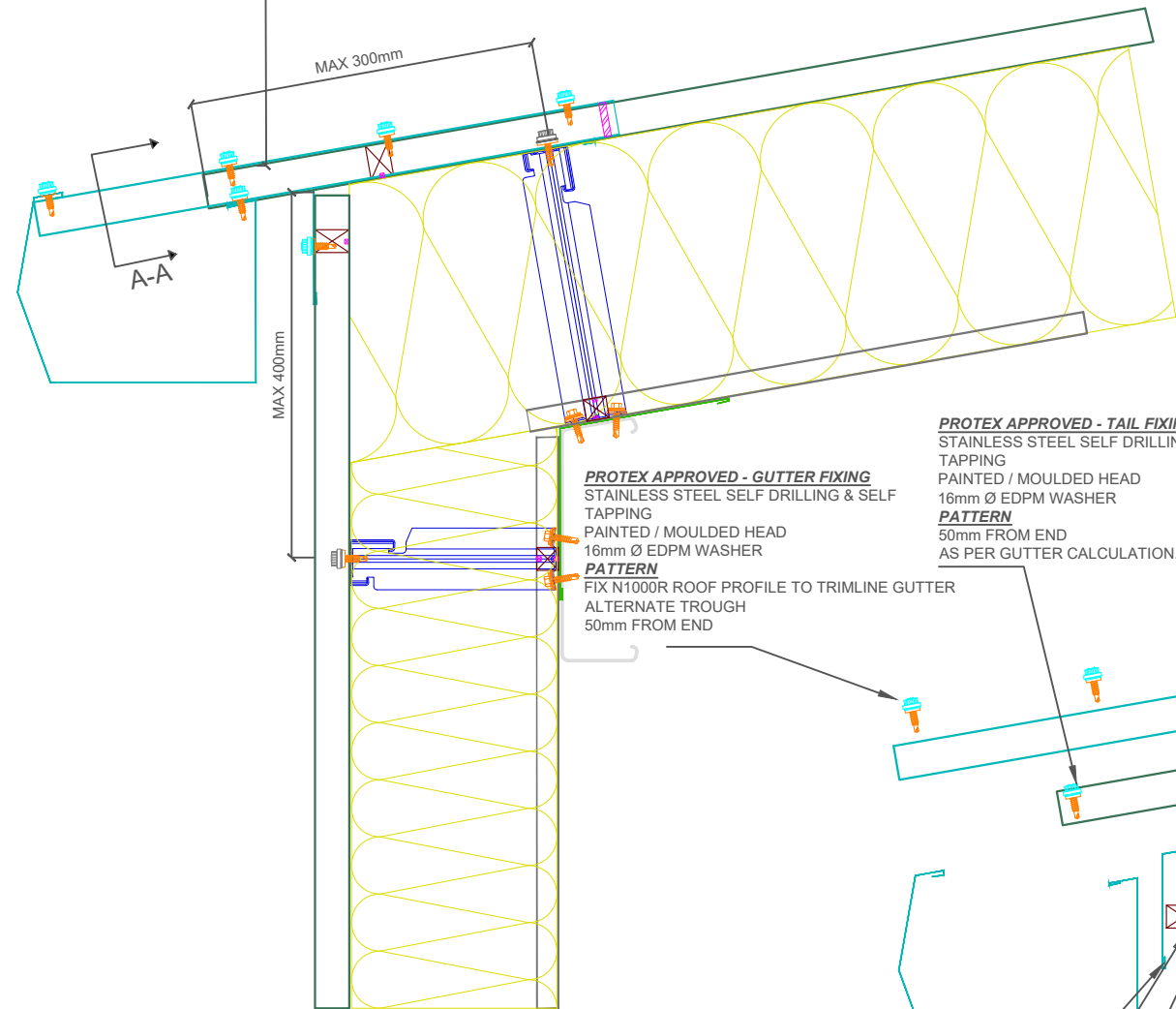

PROTEX APPROVED - GUTTER ARM SEALANT
 BUTYL TAPE
LOCATION
 2NO. CONTINUOUS RUNS ALONG CROWN OF PROFILE

PROTEX APPROVED - TRIMLINE GUTTER
 COATING - PROTEX APPROVED
 GAUGE - 0.7mm
 GUTTER SIZE AS PER CALCULATIONS

PROTEX APPROVED - EXTERNAL EAVES FLASHING
 COATING - PROTEX APPROVED
 GAUGE - 0.7mm

PROTEX APPROVED - VENTED FOAM FILLER
 PROFILE - N1000C
 COLOUR - BLACK
 VENTED AT TOP OF FILLER
LOCATION
 50mm SET BACK FROM EDGE

PROTEX APPROVED - VENTED FOAM FILLER SEALANT
 GUN GRADE BUTYL
 APPROX 4mm DIAMETER BEAD
LOCATION
 CONTINUOUS RUN BOTTOM OF FOAM FILLER

PRX-WS-01 WALL SYSTEM

PROTEX APPROVED - TAIL FIXING
 STAINLESS STEEL SELF DRILLING & SELF TAPPING
 PAINTED / MOULDED HEAD
 16mm Ø EDPM WASHER
PATTERN
 50mm FROM END
 AS PER GUTTER CALCULATION.

PROTEX APPROVED - GUTTER FIXING
 STAINLESS STEEL SELF DRILLING & SELF TAPPING
 PAINTED / MOULDED HEAD
 16mm Ø EDPM WASHER
PATTERN
 FIX N1000R ROOF PROFILE TO TRIMLINE GUTTER
 ALTERNATE TROUGH
 50mm FROM END

PROTEX APPROVED - GUTTER ARM FIXING
 COATING - PROTEX APPROVED
 COLOUR TO MATCH ROOF
 LENGTH AS PER CALCULATION
PATTERN
 AS PER LAYOUT CALCULATION

PROTEX APPROVED - GUTTER ARM FIXING
 STAINLESS STEEL SELF DRILLING & SELF TAPPING
 PAINTED / MOULDED HEAD
 16mm Ø EDPM WASHER
PATTERN
 AS PER LAYOUT CALCULATION

PROTEX APPROVED - GUTTER ARM SEALANT
 BUTYL TAPE
LOCATION
 CONTINUOUS RUN.
 TOP EDGE OF GUTTER ARM
 WEATHER SIDE OF FIXING

PROTEX APPROVED SPACER SYSTEM
 BRACKET DEPTH TO SUIT U-VALUE CALCULATIONS
 MINIMUM DEPTH 120mm
PATTERN
 MAX RAIL CENTRE'S 1800mm
 MAX BRACKET CENTRE'S 1000mm
 BRACKET CENTRE'S TO SUIT LOADING CALCULATIONS
 BRACKET MUST BE PLACED WITHIN 100mm OF MALE END OF SPACER SYSTEM JOINT AND BAR END

PROTEX APPROVED - GLASS FIBRE INSULATION
 THICKNESS TO SUIT U-VALUE REQUIREMENT
 MINIMUM THICKNESS - 120mm
 FIRE CLASS A1 TO EN 13501-1
 MANUFACTURED IN ACCORDANCE WITH BS EN 13162
 (SUGGESTED THICKNESS TO BE >10% THAN SPACER SYSTEM DEPTH.)

N1000L+ INTERNAL LINER PROFILE
 GAUGE - 0.4mm
 COATING - BRIGHT WHITE LINER LINER

PROTEX APPROVED - FOAM FILLER
 PROFILE - N1000L+
 COLOUR - WHITE
LOCATION
 50mm SET BACK FROM EDGE

PROTEX APPROVED - FOAM FILLER SEALANT
 GUN GRADE BUTYL
 APPROX 4mm DIAMETER BEAD
LOCATION
 CONTINUOUS RUNS TOP & BOTTOM OF FOAM FILLER

PROTEX APPROVED - INTERNAL EAVES FLASHINGS
 THICKNESS - 0.7mm
 COLOUR - BRIGHT WHITE LINER
 COATING - PROTEX APPROVED

PROTEX APPROVED - LINER MAIN FIXING
 STAINLESS STEEL SELF DRILLING & SELF TAPPING
 16mm Ø EDPM WASHER
PATTERN
 SHEET ENDS - EVERY TROUGH - 6 NO. FIXINGS
 INTERMEDIATE SUPPORTS - ALTERNATE TROUGH - 4 NO. FIXINGS

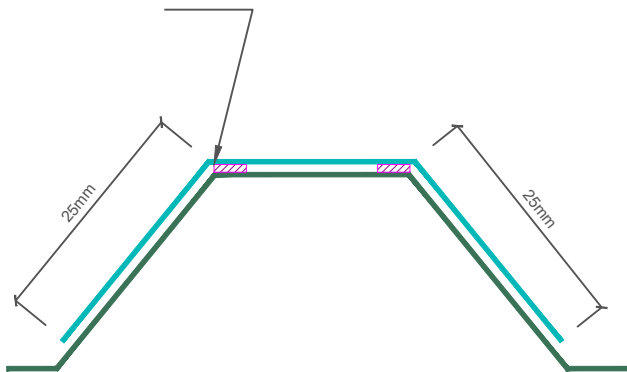

A-A

- INSTALLATION NOTES**
- FLASHING JOINTS SEALED WITH BUTYL
 - FLASHING JOINTS FIXED AT 100mm CENTRES (RIVET OR STITCH)
 - FLASHINGS FIXED AT 450mm CENTRES
 - BRACKET MUST BE POSITIONED WITHIN 100mm OF END OF BAR OR MALE END JOINT
 - NO IMPACT DRIVERS OR CLUTCHLESS DRILLS
 - NO CARBON FIXINGS

REV	DATE	DESCRIPTION

FirthSteels[®]
 Firth Steels Ltd, Calderbank, River Street, Brighouse, West Yorkshire HD6 1LU
 Technical@firth-steels.co.uk +44 1484 405940 Firth-steels.co.uk

SGS SGS SGS UKAS
 PlanetMark

PROTEX[®]
 UKCA
 LPCB
 UKAS
 LPS 1181 Cert/LPCB ref 1811a

This draft drawing has been supplied by Firth Steels Ltd for guidance purposes only and is provided free of charge. It represents a suggested typical detail and should not be assumed as suitable for any specific project or application. It is essential to read this in conjunction with the Protex System specification documents to ensure completeness of information.
 Please note, no responsibility is assumed for errors or misinterpretations resulting from the information contained within this drawing. Details depicted are for illustration purposes only, and no liability is accepted for their use. Firth Steels reserves the right to modify details without notice. This drawing is the property of Firth Steels Ltd, any reproduction without explicit written consent is prohibited.
 Firth Steels is committed to ongoing improvement. The details and data shared in this document are reflective of the current state as of the issue date. It is the duty of the recipients to ensure that the information in this document is still up-to-date at the time of its use.

Drawing Number
Protex-RS02-7 Trimline Gutter

Drawn by TO Checked by KP Date 24/09/2024

Project Title PRX-RS-02 Size A3 Revision A

<<< DO NOT SCALE FROM THIS DRAWING >>>

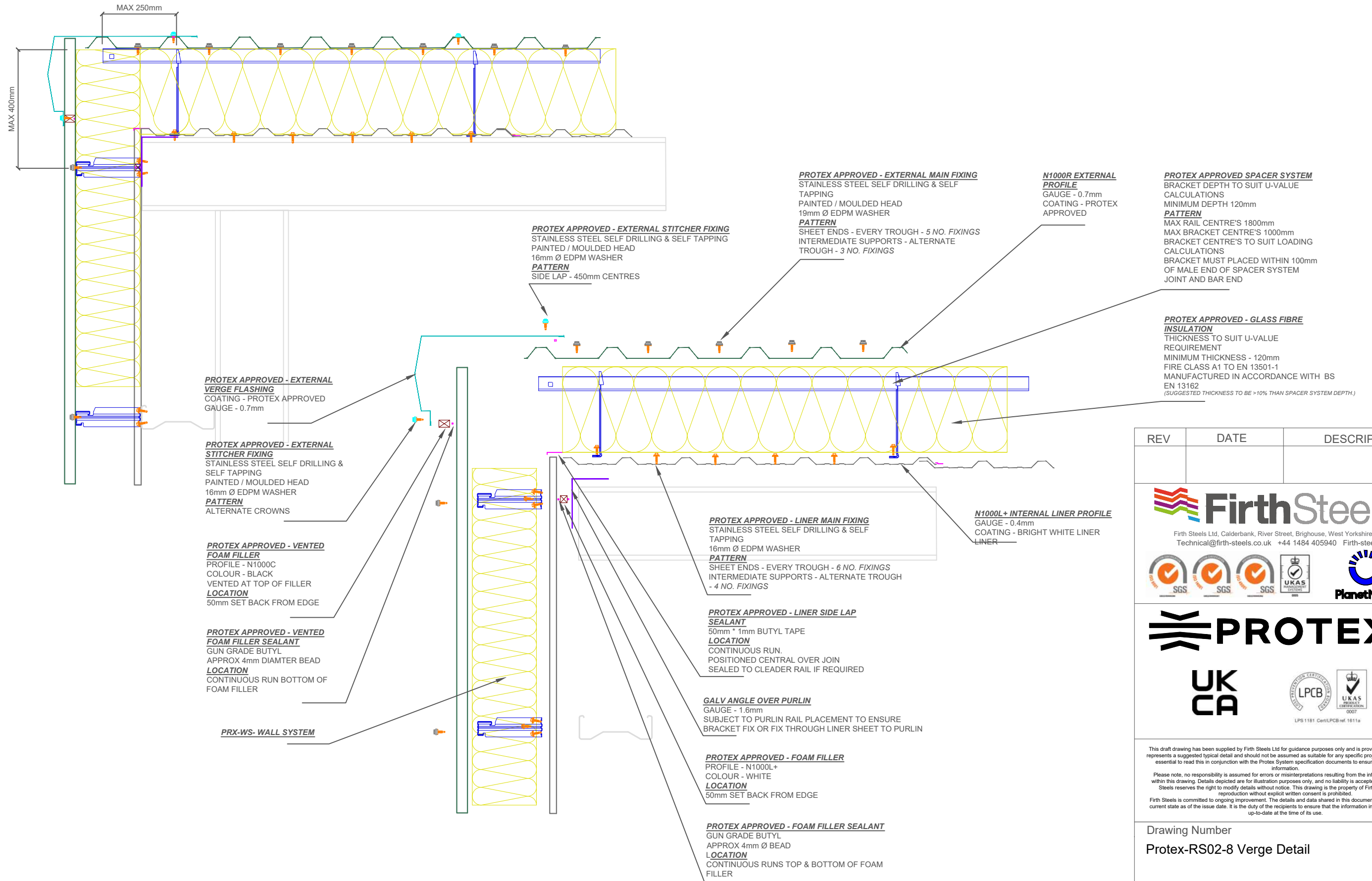

- INSTALLATION NOTES**
- FLASHING JOINTS SEALED WITH BUTYL
 - FLASHING JOINTS FIXED AT 100mm CENTRES (RIVET OR STITCH)
 - FLASHINGS FIXED AT 450mm CENTRES
 - BRACKET MUST BE POSITIONED WITHIN 100mm OF END OF BAR OR MALE END JOIN
 - NO IMPACT DRIVERS OR CLUTCHLESS DRILLS
 - NO CARBON FIXINGS

REV	DATE	DESCRIPTION

FirthSteels[®]
 Firth Steels Ltd, Calderbank, River Street, Brighouse, West Yorkshire HD6 1LU
 Technical@firth-steels.co.uk +44 1484 405940 Firth-steels.co.uk

SGS SGS SGS UKAS
 PlanetMark

PROTEX[®]

UK CA
 LPCB
 UKAS
 LPS 1181 Cert/LPCB ref: 1611a

This draft drawing has been supplied by Firth Steels Ltd for guidance purposes only and is provided free of charge. It represents a suggested typical detail and should not be assumed as suitable for any specific project or application. It is essential to read this in conjunction with the Protex System specification documents to ensure completeness of information.

Please note, no responsibility is assumed for errors or misinterpretations resulting from the information contained within this drawing. Details depicted are for illustration purposes only, and no liability is accepted for their use. Firth Steels reserves the right to modify details without notice. This drawing is the property of Firth Steels Ltd, any reproduction without explicit written consent is prohibited.

Firth Steels is committed to ongoing improvement. The details and data shared in this document are reflective of the current state as of the issue date. It is the duty of the recipients to ensure that the information in this document is still up-to-date at the time of its use.

Drawing Number
Protex-RS02-8 Verge Detail

Drawn by TO	Checked by KP	Date 24/09/2024
Project Title PRX-RS-02	Size A3	Revision A

<<< DO NOT SCALE FROM THIS DRAWING >>>

PROTEX APPROVED - EXTERNAL STITCHER FIXING
 STAINLESS STEEL SELF DRILLING & SELF TAPPING
 PAINTED / MOULDED HEAD
 16mm Ø EDPM WASHER
PATTERN
 SIDE LAP - 450mm CENTRES

PROTEX APPROVED - EXTERNAL VERGE FLASHING
 COATING - PROTEX APPROVED
 GAUGE - 0.7mm
 ALL JOINTS TO BE SEALED

PROTEX APPROVED - EXTERNAL MAIN FIXING
 STAINLESS STEEL SELF DRILLING & SELF TAPPING
 PAINTED / MOULDED HEAD
 19mm Ø EDPM WASHER
PATTERN
 SHEET ENDS - EVERY TROUGH - 5 NO. FIXINGS
 INTERMEDIATE SUPPORTS - ALTERNATE TROUGH - 3 NO. FIXINGS

N1000R EXTERNAL PROFILE
 GAUGE - 0.7mm
 COATING - PROTEX APPROVED

PROTEX APPROVED - VENTED FOAM FILLER
 PROFILE - N1000C
 COLOUR - BLACK
 VENTED AT TOP OF FILLER
LOCATION
 50mm SET BACK FROM EDGE

PROTEX APPROVED - FOAM FILLER
 PROFILE - N1000L+
 COLOUR - WHITE
LOCATION
 50mm SET BACK FROM EDGE

PROTEX APPROVED - FOAM FILLER SEALANT
 GUN GRADE BUTYL
 APPROX 4mm DIAMETER BEAD
LOCATION
 CONTINUOUS RUNS TOP & BOTTOM OF FOAM FILLER

PRX-WS-01 WALL SYSTEM

PROTEX APPROVED - LINER SIDE LAP SEALANT
 50mm* 1mm BUTYL TAPE
LOCATION
 CONTINUOUS RUN.
 POSITIONED CENTRAL OVER JOIN

PROTEX APPROVED - INTERNAL VERGE FLASHING
 FLASHING
 THICKNESS - 0.7mm
 COLOUR - BRIGHT WHITE LINER
 ALL JOINTS TO BE SEALED

PROTEX APPROVED - FLASHING SEALANT
 GUN GRADE BUTYL
 APPROX 4mm DIAMETER BEAD
LOCATION
 CONTINUOUS RUN





N1000L+ INTERNAL LINER PROFILE
 GAUGE - 0.4mm
 COATING - BRIGHT WHITE LINER
 LINER

PROTEX APPROVED - LINER MAIN FIXING
 STAINLESS STEEL SELF DRILLING & SELF TAPPING
 16mm Ø EDPM WASHER
PATTERN
 SHEET ENDS - EVERY TROUGH - 6 NO. FIXINGS
 INTERMEDIATE SUPPORTS - ALTERNATE TROUGH - 4 NO. FIXINGS

PROTEX APPROVED SPACER SYSTEM
 BRACKET DEPTH TO SUIT U-VALUE CALCULATIONS
 MINIMUM DEPTH 120mm
PATTERN
 MAX RAIL CENTRE'S 1800mm
 MAX BRACKET CENTRE'S 1000mm
 BRACKET CENTRE'S TO SUIT LOADING CALCULATIONS
 BRACKET MUST BE PLACED WITHIN 100mm OF MALE END OF SPACER SYSTEM JOINT AND BAR END

PROTEX APPROVED - GLASS FIBRE INSULATION
 THICKNESS TO SUIT U-VALUE REQUIREMENT
 MINIMUM THICKNESS - 120mm
 FIRE CLASS A1 TO EN 13501-1
 MANUFACTURED IN ACCORDANCE WITH BS EN 13162
 (SUGGESTED THICKNESS TO BE >10% THAN SPACER SYSTEM DEPTH.)

- INSTALLATION NOTES**
- FLASHING JOINTS SEALED WITH BUTYL
 - FLASHING JOINTS FIXED AT 100mm CENTRES (RIVET OR STITCH)
 - FLASHINGS FIXED AT 450mm CENTRES
 - BRACKET MUST BE POSITIONED WITHIN 100mm OF END OF BAR OR MALE END JOINT
 - NO IMPACT DRIVERS OR CLUTCHLESS DRILLS
 - NO CARBON FIXINGS

REV	DATE	DESCRIPTION
 <p>Firth Steels Ltd, Calderbank, River Street, Brighouse, West Yorkshire HD6 1LU Technical@firth-steels.co.uk +44 1484 405940 Firth-steels.co.uk</p> 		
   <p>LPS 1181 Cert/LPCB ref 1811a</p>		
<p>This draft drawing has been supplied by Firth Steels Ltd for guidance purposes only and is provided free of charge. It represents a suggested typical detail and should not be assumed as suitable for any specific project or application. It is essential to read this in conjunction with the Protex System specification documents to ensure completeness of information.</p> <p>Please note, no responsibility is assumed for errors or misinterpretations resulting from the information contained within this drawing. Details depicted are for illustration purposes only, and no liability is accepted for their use. Firth Steels reserves the right to modify details without notice. This drawing is the property of Firth Steels Ltd, any reproduction without explicit written consent is prohibited.</p> <p>Firth Steels is committed to ongoing improvement. The details and data shared in this document are reflective of the current state as of the issue date. It is the duty of the recipients to ensure that the information in this document is still up-to-date at the time of its use.</p>		
<p>Drawing Number Protex-RS02-9 Parapet Upstand Verge</p>		
Drawn by TO	Checked by KP	Date 24/09/2024
Project Title PRX-RS-02		Size A3
		Revision A
<p><<< DO NOT SCALE FROM THIS DRAWING >>></p>		

N1000R EXTERNAL CURVED EAVES PROFILE
GAUGE - 0.7mm
COATING - PROTEX APPROVED

PROTEX APPROVED - VENTED FOAM FILLER SEALANT
GUN GRADE BUTYL
APPROX 4mm DIAMETER BEAD
LOCATION
CONTINUOUS RUN BOTTOM OF FOAM FILLER

PROTEX APPROVED - EXTERNAL MAIN FIXING
STAINLESS STEEL SELF DRILLING & SELF TAPPING
PAINTED / MOULDED HEAD
19mm Ø EDPM WASHER
PATTERN
SHEET ENDS - EVERY TROUGH - 5 NO. FIXINGS

PROTEX APPROVED - EXTERNAL GUTTER FLASHING
COATING - PROTEX APPROVED
GAUGE - 0.7mm

PROTEX APPROVED - VENTED FOAM FILLER
PROFILE - N1000R
COLOUR - BLACK
VENTED AT TOP OF FILLER
LOCATION
50mm SET BACK FROM EDGE

PROTEX APPROVED - FOAM FILLER
PROFILE - N1000L+
COLOUR - WHITE
LOCATION
50mm SET BACK FROM EDGE

PROTEX APPROVED - FOAM FILLER SEALANT
GUN GRADE BUTYL
APPROX 4mm DIAMETER BEAD
LOCATION
CONTINUOUS RUNS TOP & BOTTOM OF FOAM FILLER

PROTEX APPROVED - EXTERNAL STITCHER FIXING
STAINLESS STEEL SELF DRILLING & SELF TAPPING
PAINTED / MOULDED HEAD
16mm Ø EDPM WASHER
PATTERN
SIDE LAP - 450mm CENTRES DOWN CURVE

PROTEX APPROVED - CURVED SIDE LAP SEALANT
6mm * 5mm BUTYL TAPE
LOCATION
CONTINUOUS RUN UNTIL 90° OF WALL REACHED.
POSITIONED WEATHER SIDE OF FIXING

PROTEX APPROVED SPACER SYSTEM
BRACKET DEPTH TO SUIT U-VALUE CALCULATIONS
MINIMUM DEPTH 120mm
PATTERN
MAX RAIL CENTRE'S 1800mm
MAX BRACKET CENTRE'S 1000mm
BRACKET CENTRE'S TO SUIT LOADING CALCULATIONS
BRACKET MUST BE PLACED WITHIN 100mm OF MALE END OF SPACER SYSTEM JOINT AND BAR END

PRX - RS ROOF SYSTEM

PROTEX APPROVED - LINER MAIN FIXING
STAINLESS STEEL SELF DRILLING & SELF TAPPING
16mm Ø EDPM WASHER
PATTERN
SHEET ENDS - EVERY TROUGH - 6 NO. FIXINGS
INTERMEDIATE SUPPORTS - ALTERNATE TROUGH - 4 NO. FIXINGS

N1000L+ INTERNAL LINER PROFILE
GAUGE - 0.4mm
COATING - BRIGHT WHITE LINER LINER

PROTEX APPROVED - GLASS FIBRE INSULATION
THICKNESS TO SUIT U-VALUE REQUIREMENT
MINIMUM THICKNESS - 120mm
FIRE CLASS A1 TO EN 13501-1
MANUFACTURED IN ACCORDANCE WITH BS EN 13162 (SUGGESTED THICKNESS TO BE >10% THAN SPACER SYSTEM DEPTH.)

PROTEX APPROVED GUTTER SYSTEM

- INSTALLATION NOTES**
- FLASHING JOINTS SEALED WITH BUTYL
 - FLASHING JOINTS FIXED AT 100mm CENTRES (RIVET OR STITCH)
 - FLASHINGS FIXED AT 450mm CENTRES
 - BRACKET MUST BE POSITIONED WITHIN 100mm OF END OF BAR OR MALE END JOIN
 - NO IMPACT DRIVERS OR CLUTCHLESS DRILLS
 - NO CARBON FIXINGS

REV	DATE	DESCRIPTION

FirthSteels[®]
Firth Steels Ltd, Calderbank, River Street, Brighouse, West Yorkshire HD6 1LU
Technical@firth-steels.co.uk +44 1484 405940 Firth-steels.co.uk



PROTEX[®]

UK CA



This draft drawing has been supplied by Firth Steels Ltd for guidance purposes only and is provided free of charge. It represents a suggested typical detail and should not be assumed as suitable for any specific project or application. It is essential to read this in conjunction with the Protex System specification documents to ensure completeness of information.
Please note, no responsibility is assumed for errors or misinterpretations resulting from the information contained within this drawing. Details depicted are for illustration purposes only, and no liability is accepted for their use. Firth Steels reserves the right to modify details without notice. This drawing is the property of Firth Steels Ltd, any reproduction without explicit written consent is prohibited.
Firth Steels is committed to ongoing improvement. The details and data shared in this document are reflective of the current state as of the issue date. It is the duty of the recipients to ensure that the information in this document is still up-to-date at the time of its use.

Drawing Number
Protex-RS02-10 Curved Eaves With Gutter

Drawn by TO Checked by KP Date 24/09/2024

Project Title PRX-RS-02 Size A3 Revision A

<<< DO NOT SCALE FROM THIS DRAWING >>>

PROTEX APPROVED - CURVED SIDE LAP SEALANT

6mm x 5mm BUTYL TAPE
LOCATION
 CONTINUOUS RUN UNTIL 90° OF WALL REACHED.
 POSITIONED WEATHER SIDE OF FIXING

PROTEX APPROVED SPACER SYSTEM

BRACKET DEPTH TO SUIT U-VALUE CALCULATIONS
 MINIMUM DEPTH 120mm
PATTERN
 MAX RAIL CENTRE'S 1800mm
 MAX BRACKET CENTRE'S 1000mm
 BRACKET CENTRE'S TO SUIT LOADING CALCULATIONS
 BRACKET MUST BE PLACED WITHIN 100mm OF MALE END OF SPACER SYSTEM JOINT AND BAR END

PROTEX APPROVED - EXTERNAL STITCHER FIXING

STAINLESS STEEL SELF DRILLING & SELF TAPPING PAINTED / MOULDED HEAD
 16mm Ø EDPM WASHER
PATTERN
 SIDE LAP - 450mm CENTRES DOWN CURVE

PROTEX APPROVED - EXTERNAL MAIN FIXING

STAINLESS STEEL SELF DRILLING & SELF TAPPING PAINTED / MOULDED HEAD
 19mm Ø EDPM WASHER
PATTERN
 SHEET ENDS - EVERY TROUGH - 5 NO. FIXINGS

EXTERNAL CURVED EAVE PROFILE
 GAUGE - 0.7mm
 COATING - PROTEX APPROVED

N1000L+ INTERNAL LINER CURVED PROFILE
 GAUGE - 0.4mm
 COATING - BRIGHT WHITE LINER LINER

PROTEX APPROVED - GLASS FIBRE INSULATION

THICKNESS TO SUIT U-VALUE REQUIREMENT
 MINIMUM THICKNESS - 120mm
 FIRE CLASS A1 TO EN 13501-1
 MANUFACTURED IN ACCORDANCE WITH BS EN 13162
 (SUGGESTED THICKNESS TO BE >10% THAN SPACER SYSTEM DEPTH.)

PRX-WS WALL SYSTEM or PRX - RS ROOF SYSTEM

INSTALLATION NOTES

- FLASHING JOINTS SEALED WITH BUTYL
- FLASHING JOINTS FIXED AT 100mm CENTRES (RIVET OR STITCH)
- FLASHINGS FIXED AT 450mm CENTRES
- BRACKET MUST BE POSITIONED WITHIN 100mm OF END OF BAR OR MALE END JOINT
- NO IMPACT DRIVERS OR CLUTCHLESS DRILLS
- NO CARBON FIXINGS

REV	DATE	DESCRIPTION

FirthSteels[®]

Firth Steels Ltd, Calderbank, River Street, Brighouse, West Yorkshire HD6 1LU
 Technical@firth-steels.co.uk +44 1484 405940 Firth-steels.co.uk



PROTEX[®]

UK CA



This draft drawing has been supplied by Firth Steels Ltd for guidance purposes only and is provided free of charge. It represents a suggested typical detail and should not be assumed as suitable for any specific project or application. It is essential to read this in conjunction with the Protex System specification documents to ensure completeness of information.

Please note, no responsibility is assumed for errors or misinterpretations resulting from the information contained within this drawing. Details depicted are for illustration purposes only, and no liability is accepted for their use. Firth Steels reserves the right to modify details without notice. This drawing is the property of Firth Steels Ltd, any reproduction without explicit written consent is prohibited.

Firth Steels is committed to ongoing improvement. The details and data shared in this document are reflective of the current state as of the issue date. It is the duty of the recipients to ensure that the information in this document is still up-to-date at the time of its use.

Drawing Number
Protex-RS02-11 Curved Eaves

Drawn by TO	Checked by KP	Date 24/09/2024
----------------	------------------	--------------------

Project Title PRX-RS-02	Size A3	Revision A
----------------------------	------------	---------------

<<< DO NOT SCALE FROM THIS DRAWING >>>

PROTEX APPROVED - EXTERNAL MAIN FIXING
 STAINLESS STEEL SELF DRILLING & SELF TAPPING
 PAINTED / MOULDED HEAD
 19mm Ø EDPM WASHER
PATTERN
 SHEET ENDS - EVERY TROUGH - 5 NO. FIXINGS
 INTERMEDIATE SUPPORTS - ALTERNATE TROUGH - 3 NO. FIXINGS

PROTEX APPROVED - EXTERNAL STITCHER FIXING
 STAINLESS STEEL SELF DRILLING & SELF TAPPING
 PAINTED / MOULDED HEAD
 16mm Ø EDPM WASHER
PATTERN
 450mm CENTRES AND AT EVERY FLASHING JOINT

N1000R EXTERNAL PROFILE
 GAUGE - 0.7mm
 COATING - PROTEX APPROVED

PROTEX APPROVED SPACER SYSTEM
 BRACKET DEPTH TO SUIT U-VALUE CALCULATIONS
 MINIMUM DEPTH 120mm
PATTERN
 MAX RAIL CENTRE'S 1800mm
 MAX BRACKET CENTRE'S 1000mm
 BRACKET CENTRE'S TO SUIT LOADING CALCULATIONS
 BRACKET MUST PLACED WITHIN 100mm OF MALE END OF SPACER SYSTEM JOINT AND BAR END

PROTEX APPROVED - BRACKET FIXING
 STAINLESS STEEL SELF DRILLING & SELF TAPPING
 16mm Ø EDPM WASHER
PATTERN
 AS PER LAYOUT CALCULATIONS

PROTEX APPROVED - GLASS FIBRE INSULATION
 THICKNESS TO SUIT U-VALUE REQUIREMENT
 MINIMUM THICKNESS - 120mm
 FIRE CLASS A1 TO EN 13501-1
 MANUFACTURED IN ACCORDANCE WITH BS EN 13162
 (SUGGESTED THICKNESS TO BE >10% THAN SPACER SYSTEM DEPTH.)

PROTEX APPROVED FOAM FILLER
 PROFILE - N1000L+
 COLOUR - WHITE
LOCATION
 50mm SET BACK FROM EDGE

PROTEX APPROVED - FOAM FILLER SEALANT
 GUN GRADE BUTYL
 APPROX 4mm DIAMTER BEAD
LOCATION
 CONTINUOUS RUNS TOP & BOTTOM OF FOAM FILLER

PROTEX APPROVED INTERNAL GUTTER FLASHING
 GAUGE - 0.7mm
 COATING - BRIGHT WHITE LINER LINER
 REQUIRED IF CAVITY OVER 260mm

PROTEX APPROVED - VENTED FOAM FILLER SEALANT
 GUN GRADE BUTYL
 APPROX 4mm DIAMTER BEAD
LOCATION
 CONTINUOUS RUN BOTTOM OF FOAM FILLER

PROTEX APPROVED - VENTED FOAM FILLER
 PROFILE - N1000R
 COLOUR - BLACK
 VENTED AT TOP OF FILLER
LOCATION
 50mm SET BACK FROM EDGE

PROTEX APPROVED FOAM FILLER SEALANT
 GUN GRADE BUTYL
 APPROX 4mm DIAMTER BEAD
LOCATION
 CONTINUOUS RUNS TOP & BOTTOM OF FOAM FILLER

PROTEX APPROVED - MEMBRANE GUTTER
 SPECIFIED BY OTHERS

PROTEX APPROVED - GUTTER COVER FLASHINGS
 THICKNESS - 0.7mm
 COATING - PROTEX APPROVED

PROTEX APPROVED - LINER MAIN FIXING
 STAINLESS STEEL SELF DRILLING & SELF TAPPING
 16mm Ø EDPM WASHER
PATTERN
 SHEET ENDS - EVERY TROUGH - 6 NO. FIXINGS
 INTERMEDIATE SUPPORTS - ALTERNATE TROUGH - 4 NO. FIXINGS

- INSTALLATION NOTES**
- FLASHING JOINTS SEALED WITH BUTYL
 - FLASHING JOINTS FIXED AT 100mm CENTRES (RIVET OR STITCH)
 - FLASHINGS FIXED AT 450mm CENTRES
 - BRACKET MUST BE POSITIONED WITHIN 100mm OF END OF BAR OR MALE END JOINT
 - NO IMPACT DRIVERS OR CLUTCHLESS DRILLS
 - NO CARBON FIXINGS

REV	DATE	DESCRIPTION

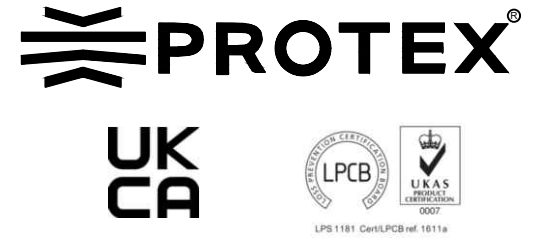

This draft drawing has been supplied by Firth Steels Ltd for guidance purposes only and is provided free of charge. It represents a suggested typical detail and should not be assumed as suitable for any specific project or application. It is essential to read this in conjunction with the Protex System specification documents to ensure completeness of information.
 Please note, no responsibility is assumed for errors or misinterpretations resulting from the information contained within this drawing. Details depicted are for illustration purposes only, and no liability is accepted for their use. Firth Steels reserves the right to modify details without notice. This drawing is the property of Firth Steels Ltd, any reproduction without explicit written consent is prohibited.
 Firth Steels is committed to ongoing improvement. The details and data shared in this document are reflective of the current state as of the issue date. It is the duty of the recipients to ensure that the information in this document is still up-to-date at the time of its use.

Drawing Number
Protex-RS02-12 Valley Gutter

Drawn by TO	Checked by KP	Date 24/09/2024
----------------	------------------	--------------------

Project Title PRX-RS-02	Size A3	Revision A
----------------------------	------------	---------------

<<< DO NOT SCALE FROM THIS DRAWING >>>

PROTEX APPROVED - GLASS FIBRE INSULATION
 THICKNESS TO SUIT U-VALUE REQUIREMENT
 MINIMUM THICKNESS - 120mm
 FIRE CLASS A1 TO EN 13501-1
 MANUFACTURED IN ACCORDANCE WITH BS EN 13162
 (SUGGESTED THICKNESS TO BE >10% THAN SPACER SYSTEM DEPTH.)

PROTEX APPROVED - EXTERNAL MAIN FIXING
 STAINLESS STEEL SELF DRILLING & SELF TAPPING
 PAINTED / MOULDED HEAD
 19mm Ø EDPM WASHER
PATTERN
 SHEET ENDS - EVERY TROUGH - 5 NO. FIXINGS
 INTERMEDIATE SUPPORTS - ALTERNATE TROUGH - 3 NO. FIXINGS

PROTEX APPROVED - VENTED FOAM FILLER SEALANT
 GUN GRADE BUTYL
 APPROX 4mm DIAMTER BEAD
LOCATION
 CONTINUOUS RUN BOTTOM OF FOAM FILLER

PROTEX APPROVED - GLASS FIBRE INSULATION
 THICKNESS TO SUIT U-VALUE REQUIREMENT
 MINIMUM THICKNESS - 120mm
 FIRE CLASS A1 TO EN 13501-1
 MANUFACTURED IN ACCORDANCE WITH BS EN 13162
 (SUGGESTED THICKNESS TO BE >10% THAN SPACER SYSTEM DEPTH.)

PROTEX APPROVED - BRACKET FIXING
 STAINLESS STEEL SELF DRILLING & SELF TAPPING
 16mm Ø EDPM WASHER
PATTERN
 AS PER LAYOUT CALCULATIONS

PRX-WS-01 WALL SYSTEM

PROTEX APPROVED SPACER SYSTEM
 BRACKET DEPTH TO SUIT U-VALUE CALCULATIONS
 MINIMUM DEPTH 120mm
PATTERN
 MAX RAIL CENTRE'S 1800mm
 MAX BRACKET CENTRE'S 1000mm
 BRACKET CENTRE'S TO SUIT LOADING CALCULATIONS
 BRACKET MUST BE PLACED WITHIN 100mm OF MALE END OF SPACER SYSTEM JOINT AND BAR END

PROTEX APPROVED - GUTTER COVER FLASHINGS
 THICKNESS - 0.7mm
 COATING - PROTEX APPROVED

PROTEX APPROVED SEALANT
 50mm * 1mm BUTYL TAPE
LOCATION
 BETWEEN GUTTER AND RAIL

PROTEX APPROVED INTERNAL PARAPET FLASHING
 GAUGE - 0.7mm
 COATING - BRIGHT WHITE LINER
 LINER
 REQUIRED INTERNALLY TO CAP OFF INSULATION

PROTEX APPROVED - MEMBRANE GUTTER
 SPECIFIED BY OTHERS

PROTEX APPROVED - VENTED FOAM FILLER
 PROFILE - N1000R
 COLOUR - BLACK
 VENTED AT TOP OF FILLER
LOCATION
 50mm SET BACK FROM EDGE

PROTEX APPROVED FOAM FILLER SEALANT
 GUN GRADE BUTYL
 APPROX 4mm DIAMTER BEAD
LOCATION
 CONTINUOUS RUNS TOP & BOTTOM OF FOAM FILLER

PROTEX APPROVED - LINER MAIN FIXING
 STAINLESS STEEL SELF DRILLING & SELF TAPPING
 16mm Ø EDPM WASHER
PATTERN
 SHEET ENDS - EVERY TROUGH - 6 NO. FIXINGS
 INTERMEDIATE SUPPORTS - ALTERNATE TROUGH - 4 NO. FIXINGS

PROTEX APPROVED FOAM FILLER
 PROFILE - N1000L+
 COLOUR - WHITE
LOCATION
 50mm SET BACK FROM EDGE

- INSTALLATION NOTES**
- FLASHING JOINTS SEALED WITH BUTYL
 - FLASHING JOINTS FIXED AT 100mm CENTRES (RIVET OR STITCH)
 - FLASHINGS FIXED AT 450mm CENTRES
 - BRACKET MUST BE POSITIONED WITHIN 100mm OF END OF BAR OR MALE END JOINT
 - NO IMPACT DRIVERS OR CLUTCHLESS DRILLS
 - NO CARBON FIXINGS

REV	DATE	DESCRIPTION

FirthSteels[®]
 Firth Steels Ltd, Calderbank, River Street, Brighouse, West Yorkshire HD6 1LU
 Technical@firth-steels.co.uk +44 1484 405940 Firth-steels.co.uk

SGS SGS SGS UKAS PLANETMARK

PROTEX[®]

UKAS LPCB

LPS 1181 Cert:LPCB ref: 1811a

This draft drawing has been supplied by Firth Steels Ltd for guidance purposes only and is provided free of charge. It represents a suggested typical detail and should not be assumed as suitable for any specific project or application. It is essential to read this in conjunction with the Protex System specification documents to ensure completeness of information.

Please note, no responsibility is assumed for errors or misinterpretations resulting from the information contained within this drawing. Details depicted are for illustration purposes only, and no liability is accepted for their use. Firth Steels reserves the right to modify details without notice. This drawing is the property of Firth Steels Ltd, any reproduction without explicit written consent is prohibited.

Firth Steels is committed to ongoing improvement. The details and data shared in this document are reflective of the current state as of the issue date. It is the duty of the recipients to ensure that the information in this document is still up-to-date at the time of its use.

Drawing Number
Protex-RS02-13 Boundary Wall Parapet Gutter

Drawn by TO	Checked by KP	Date 24/09/2024
----------------	------------------	--------------------

Project Title PRX-RS-02	Size A3	Revision A
----------------------------	------------	---------------

<<< DO NOT SCALE FROM THIS DRAWING >>>

TWIN SKIN PARAPET

PARAPET CAPPING - BUTT STRAP
GAUGE - 1.2mm MINIMUM

PROTEX APPROVED - EXTERNAL STITCHER
FIXING
STAINLESS STEEL SELF DRILLING & SELF TAPPING
PAINTED / MOULDED HEAD
16mm Ø EDPM WASHER
PATTERN
EITHER SIDE OF BUTT STRAP
75 - 100mm CENTRES

PROTEX APPROVED - VENTED
FOAM FILLER SEALANT
GUN GRADE BUTYL
APPROX 4mm DIAMETER BEAD
LOCATION
CONTINUOUS RUN BOTTOM OF
FOAM FILLER

PROTEX APPROVED - VENTED
FOAM FILLER
PROFILE - N1000C
COLOUR - BLACK
VENTED AT TOP OF FILLER
LOCATION
50mm SET BACK FROM EDGE

PROTEX APPROVED - FOAM FILLER
PROFILE - N1000L+
COLOUR - WHITE
LOCATION
50mm SET BACK FROM EDGE

PROTEX APPROVED - FOAM FILLER SEALANT
GUN GRADE BUTYL
APPROX 4mm DIAMETER BEAD
LOCATION
CONTINUOUS RUNS TOP & BOTTOM OF FOAM
FILLER

PROTEX APPROVED SPACER SYSTEM
BRACKET DEPTH TO SUIT U-VALUE
CALCULATIONS
MINIMUM DEPTH 120mm
PATTERN
MAX RAIL CENTRE'S 1800mm
MAX BRACKET CENTRE'S 1000mm
BRACKET CENTRE'S TO SUIT LOADING
CALCULATIONS
BRACKET MUST BE PLACED WITHIN 100mm
OF MALE END OF SPACER SYSTEM
JOINT AND BAR END

PARAPET SECONDARY SUPPORT
STRUCTURAL STEEL ANGLE SUPPORT
AS PER LAYOUT DESIGN

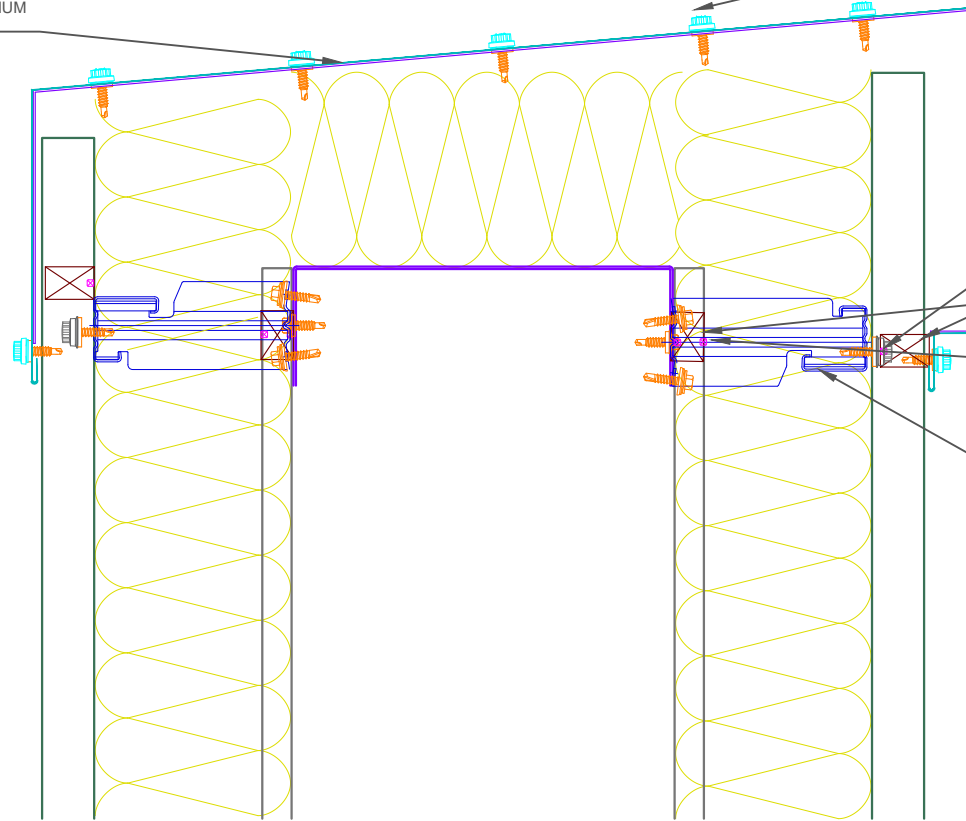

SINGLE SKIN PARAPET

PARAPET SECONDARY SUPPORT
STRUCTURAL STEEL SUPPORT
AS PER LAYOUT DESIGN

PROTEX APPROVED - EXTERNAL MAIN FIXING
STAINLESS STEEL SELF DRILLING & SELF
TAPPING
PAINTED / MOULDED HEAD
19mm Ø EDPM WASHER
PATTERN
SHEET ENDS - EVERY TROUGH - 6 NO. FIXINGS
INTERMEDIATE SUPPORTS - ALTERNATE
TROUGH - 4 NO. FIXINGS

PROTEX APPROVED - EXTERNAL
PARAPET CAPPING FLASHING
COATING - PROTEX APPROVED
GAUGE - 0.7mm

PROTEX APPROVED - EXTERNAL STITCHER
FIXING
STAINLESS STEEL SELF DRILLING & SELF TAPPING
PAINTED / MOULDED HEAD
16mm Ø EDPM WASHER
PATTERN
ALTERNATE CROWNS

PROTEX APPROVED - GLASS FIBRE
INSULATION
THICKNESS TO SUIT U-VALUE
REQUIREMENT
MINIMUM THICKNESS - 120mm
FIRE CLASS A1 TO EN 13501-1
MANUFACTURED IN ACCORDANCE WITH BS
EN 13162
(SUGGESTED THICKNESS TO BE >10% THAN SPACER SYSTEM DEPTH.)

PROTEX APPROVED INTERNAL
PARAPET FLASHING
GAUGE - 0.7mm
COATING - BRIGHT WHITE LINER
LINER
REQUIRED INTERNALLY TO CAP OFF
INSULATION

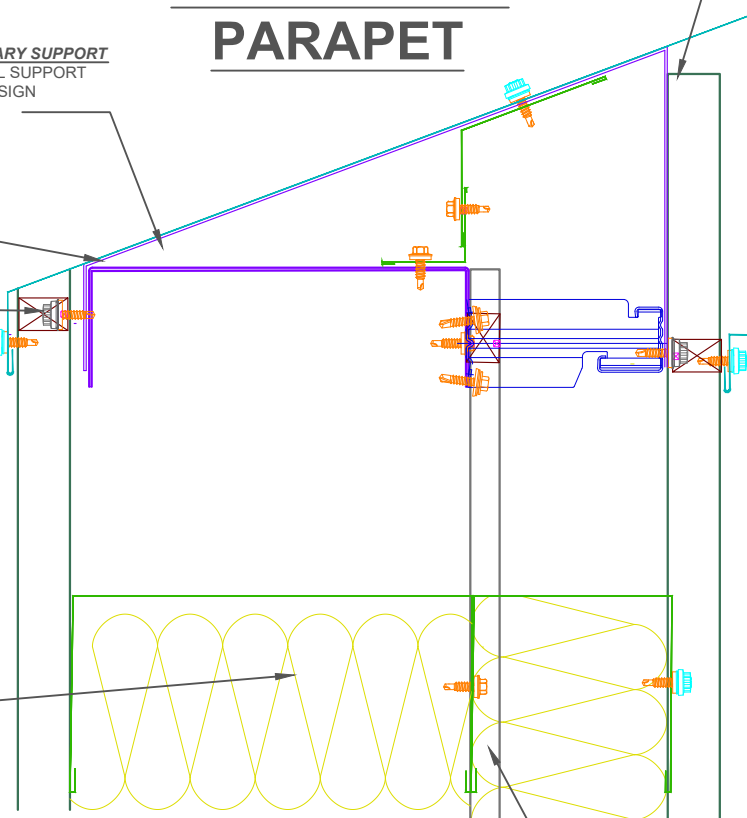

- INSTALLATION NOTES**
- FLASHING JOINTS SEALED WITH BUTYL
 - FLASHING JOINTS FIXED AT 100mm CENTRES (RIVET OR STITCH)
 - FLASHINGS FIXED AT 450mm CENTRES
 - BRACKET MUST BE POSITIONED WITHIN 100mm OF END OF BAR OR MALE END JOIN
 - NO IMPACT DRIVERS OR CLUTCHLESS DRILLS
 - NO CARBON FIXINGS

REV	DATE	DESCRIPTION

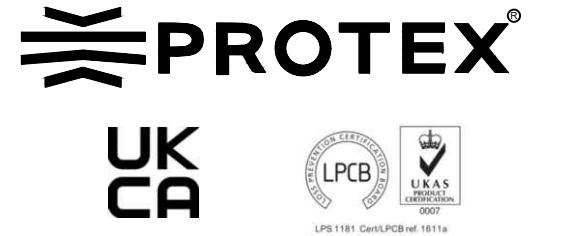

This draft drawing has been supplied by Firth Steels Ltd for guidance purposes only and is provided free of charge. It represents a suggested typical detail and should not be assumed as suitable for any specific project or application. It is essential to read this in conjunction with the Protex System specification documents to ensure completeness of information.
Please note, no responsibility is assumed for errors or misinterpretations resulting from the information contained within this drawing. Details depicted are for illustration purposes only, and no liability is accepted for their use. Firth Steels reserves the right to modify details without notice. This drawing is the property of Firth Steels Ltd, any reproduction without explicit written consent is prohibited.
Firth Steels is committed to ongoing improvement. The details and data shared in this document are reflective of the current state as of the issue date. It is the duty of the recipients to ensure that the information in this document is still up-to-date at the time of its use.

Drawing Number
Protex-RS02-14 Parapet Capping

Drawn by TO	Checked by KP	Date 24/09/2024
-----------------------	-------------------------	---------------------------

Project Title PRX-RS-02	Size A3	Revision A
-----------------------------------	-------------------	----------------------

<<< DO NOT SCALE FROM THIS DRAWING >>>

PROTEX APPROVED - EXTERNAL MAIN FIXING
 STAINLESS STEEL SELF DRILLING & SELF TAPPING
 PAINTED / MOULDED HEAD
 19mm Ø EDPM WASHER
PATTERN
 SHEET ENDS - EVERY TROUGH - 5 NO. FIXINGS
 INTERMEDIATE SUPPORTS - ALTERNATE TROUGH - 3 NO. FIXINGS

PROTEX APPROVED - GLASS FIBRE INSULATION
 THICKNESS TO SUIT U-VALUE REQUIREMENT
 MINIMUM THICKNESS - 120mm
 FIRE CLASS A1 TO EN 13501-1
 MANUFACTURED IN ACCORDANCE WITH BS EN 13162
 (SUGGESTED THICKNESS TO BE >10% THAN SPACER SYSTEM DEPTH.)

PROTEX APPROVED SPACER SYSTEM
 BRACKET DEPTH TO SUIT U-VALUE CALCULATIONS
 MINIMUM DEPTH 120mm
PATTERN
 MAX RAIL CENTRE'S 1800mm
 MAX BRACKET CENTRE'S 1000mm
 BRACKET CENTRE'S TO SUIT LOADING CALCULATIONS
 BRACKET MUST BE PLACED WITHIN 100mm OF MALE END OF SPACER SYSTEM JOINT AND BAR END

DEKTITE- PIPE EDPM PIPE SEAL

PROTEX APPROVED - EXTERNAL STITCHER FIXING
 STAINLESS STEEL SELF DRILLING & SELF TAPPING
 PAINTED / MOULDED HEAD
 16mm Ø EDPM WASHER
PATTERN
 AS PER DEKTITE SPECIFICATIONS

PROTEX APPROVED - EXTERNAL SOAKER FLASHING
 COATING - PROTEX APPROVED
 SOAKER TO BE FIT UNDERNEATH RIDGE FLASHING AND SEALED WITH 6*5mm BUTYL STRIP

PROTEX APPROVED - EXTERNAL STITCHER FIXING
 STAINLESS STEEL SELF DRILLING & SELF TAPPING
 PAINTED / MOULDED HEAD
 16mm Ø EDPM WASHER
PATTERN
 ALTERNATE CROWNS

PROTEX APPROVED - VENTED FOAM FILLER SEALANT
 GUN GRADE BUTYL
 APPROX 4mm DIAMTER BEAD
LOCATION
 CONTINUOUS RUN BOTTOM OF FOAM FILLER

PROTEX APPROVED - VENTED FOAM FILLER
 PROFILE - N1000R
 COLOUR - BLACK
 VENTED AT TOP OF FILLER
LOCATION
 50mm SET BACK FROM EDGE

PROTEX APPROVED - EXTERNAL RIDGE FLASHINGS
 THICKNESS - 0.7mm
 COATING - PROTEX APPROVED

PROTEX APPROVED - BUTYL SEALANT
 6*5mm BUTYL STRIP SEALANT
 POSITIONED AROUND COLLAR TOP AND BOTTOM

PROTEX APPROVED - INTERNAL COLLAR FLASHING
 THICKNESS - 0.7mm
 COLOUR - BRIGHT WHITE LINER
 COATING - PROTEX APPROVED

PROTEX APPROVED - FOAM FILLER
 PROFILE - N1000L+
 COLOUR - WHITE
LOCATION
 50mm SET BACK FROM EDGE

PROTEX APPROVED - FOAM FILLER SEALANT
 GUN GRADE BUTYL
 APPROX 4mm DIAMTER BEAD
LOCATION
 CONTINUOUS RUNS TOP & BOTTOM OF FOAM FILLER

PROTEX APPROVED - EXTERNAL SOAKER FLASHING
 COATING - PROTEX APPROVED
 SOAKER TO BE FIT UNDERNEATH RIDGE FLASHING AND SEALED WITH 6*5mm BUTYL STRIP

INSTALLATION NOTES

- FLASHING JOINTS SEALED WITH BUTYL
- FLASHING JOINTS FIXED AT 100mm CENTRES (RIVET OR STITCH)
- FLASHINGS FIXED AT 450mm CENTRES
- BRACKET MUST BE POSITIONED WITHIN 100mm OF END OF BAR OR MALE END JOIN
- NO IMPACT DRIVERS OR CLUTCHLESS DRILLS
- NO CARBON FIXINGS

REV	DATE	DESCRIPTION

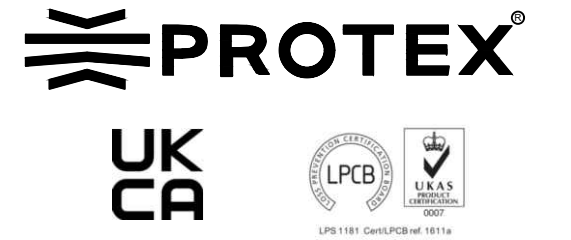

This draft drawing has been supplied by Firth Steels Ltd for guidance purposes only and is provided free of charge. It represents a suggested typical detail and should not be assumed as suitable for any specific project or application. It is essential to read this in conjunction with the Protex System specification documents to ensure completeness of information.
 Please note, no responsibility is assumed for errors or misinterpretations resulting from the information contained within this drawing. Details depicted are for illustration purposes only, and no liability is accepted for their use. Firth Steels reserves the right to modify details without notice. This drawing is the property of Firth Steels Ltd, any reproduction without explicit written consent is prohibited.
 Firth Steels is committed to ongoing improvement. The details and data shared in this document are reflective of the current state as of the issue date. It is the duty of the recipients to ensure that the information in this document is still up-to-date at the time of its use.

Drawing Number
Protex-RS02-15 Circular Penetration

Drawn by TO	Checked by KP	Date 24/09/2024
-----------------------	-------------------------	---------------------------

Project Title PRX-RS-02	Size A3	Revision A
-----------------------------------	-------------------	----------------------

<<< DO NOT SCALE FROM THIS DRAWING >>>

PROTEX APPROVED - EXTERNAL MAIN FIXING
 STAINLESS STEEL SELF DRILLING & SELF TAPPING
 PAINTED / MOULDED HEAD
 19mm Ø EDPM WASHER
PATTERN
 SHEET ENDS - EVERY TROUGH - 5 NO. FIXINGS
 INTERMEDIATE SUPPORTS - ALTERNATE TROUGH - 3 NO. FIXINGS

N1000R EXTERNAL PROFILE
 GAUGE - 0.7mm
 COATING - PROTEX APPROVED

PROTEX APPROVED - EXTERNAL FLASHING
 COATING - PROTEX APPROVED
 GAUGE - 0.7mm

PROTEX APPROVED - EXTERNAL STITCHER FIXING
 STAINLESS STEEL SELF DRILLING & SELF TAPPING
 PAINTED / MOULDED HEAD
 16mm Ø EDPM WASHER
PATTERN
 SIDE LAP - 450mm CENTRES

PROTEX APPROVED - FLASHING SEALANT
 9mm * 3mm BUTYL TAPE
LOCATION
 CONTINUOUS RUN.

PROTEX APPROVED - GLASS FIBRE INSULATION
 THICKNESS TO SUIT U-VALUE REQUIREMENT
 MINIMUM THICKNESS - 120mm
 FIRE CLASS A1 TO EN 13501-1
 MANUFACTURED IN ACCORDANCE WITH BS EN 13162
 (SUGGESTED THICKNESS TO BE >10% THAN SPACER SYSTEM DEPTH.)

PROTEX APPROVED SPACER SYSTEM
 BRACKET DEPTH TO SUIT U-VALUE CALCULATIONS
 MINIMUM DEPTH 120mm
PATTERN
 MAX RAIL CENTRE'S 1800mm
 MAX BRACKET CENTRE'S 1000mm
 BRACKET CENTRE'S TO SUIT LOADING CALCULATIONS
 BRACKET MUST BE PLACED WITHIN 100mm OF MALE END OF SPACER SYSTEM JOINT AND BAR END

N1000L+ INTERNAL LINER PROFILE
 GAUGE - 0.4mm
 COATING - BRIGHT WHITE LINER LINER

PROTEX APPROVED - LINER MAIN FIXING
 STAINLESS STEEL SELF DRILLING & SELF TAPPING
 16mm Ø EDPM WASHER
PATTERN
 SHEET ENDS - EVERY TROUGH - 6 NO. FIXINGS
 INTERMEDIATE SUPPORTS - ALTERNATE TROUGH - 4 NO. FIXINGS





PROTEX APPROVED - FLASHING SEALANT
 50mm * 1mm BUTYL TAPE
LOCATION
 CONTINUOUS RUN.

PROTEX APPROVED - FLASHING SEALANT
 GUN GRADE BUTYL
LOCATION
 CONTINUOUS RUN
 POSITIONED TO SEAL FLASHING TO MASONRY

Z GALV SPACER
 IF REQUIRED

PROTEX APPROVED - FLASHING SEALANT
 GUN GRADE BUTYL
LOCATION
 CONTINUOUS RUN
 POSITIONED TO SEAL FLASHING TO MASONRY

- INSTALLATION NOTES**
- FLASHING JOINTS SEALED WITH BUTYL
 - FLASHING JOINTS FIXED AT 100mm CENTRES (RIVET OR STITCH)
 - FLASHINGS FIXED AT 450mm CENTRES
 - BRACKET MUST BE POSITIONED WITHIN 100mm OF END OF BAR OR MALE END JOINT
 - NO IMPACT DRIVERS OR CLUTCHLESS DRILLS
 - NO CARBON FIXINGS

REV	DATE	DESCRIPTION
 <p>Firth Steels Ltd, Calderbank, River Street, Brighouse, West Yorkshire HD6 1LU Technical@firth-steels.co.uk +44 1484 405940 Firth-steels.co.uk</p> 		
  <p>LPS 1181 Cert/LPCB ref. 1611a</p>		
<p>This draft drawing has been supplied by Firth Steels Ltd for guidance purposes only and is provided free of charge. It represents a suggested typical detail and should not be assumed as suitable for any specific project or application. It is essential to read this in conjunction with the Protex System specification documents to ensure completeness of information.</p> <p>Please note, no responsibility is assumed for errors or misinterpretations resulting from the information contained within this drawing. Details depicted are for illustration purposes only, and no liability is accepted for their use. Firth Steels reserves the right to modify details without notice. This drawing is the property of Firth Steels Ltd, any reproduction without explicit written consent is prohibited.</p> <p>Firth Steels is committed to ongoing improvement. The details and data shared in this document are reflective of the current state as of the issue date. It is the duty of the recipients to ensure that the information in this document is still up-to-date at the time of its use.</p>		
<p>Drawing Number Protex-RS02-16 Abutment Detail</p>		
Drawn by TO	Checked by KP	Date 24/09/2024
Project Title PRX-RS-02		Size A3
		Revision A
<p><<< DO NOT SCALE FROM THIS DRAWING >>></p>		